

SubliJet® R

Getting Started Guide

For the Ricoh GX7000



SubliJet® R

Getting Started Guide for the Ricoh GX7000

© Copyright 2008, Sawgrass Technologies, Inc., Revision 1.0 September 2008. All rights reserved. Printed in the United States of America. **SubliJet® R** is a registered trademark of Sawgrass Technologies, Inc. Ricoh® is a registered trademarks of Ricoh Co. LTD. Other trademarks and registered trademarks are the property of their respective owners.

No part of this manual may be reproduced or transmitted in any form by any means without the prior written consent of Sawgrass Technologies, Inc. Information in this manual is subject to change without notice and does not represent a commitment on the part of Sawgrass Technologies, Inc.

IMPORTANT – READ CAREFULLY:

This Process License Agreement (“PLA”) is a legal agreement between you and Sawgrass Technologies, Inc. (“Sawgrass”). By installing the **SubliJet® R** ink in your printer, or otherwise using the Sawgrass **SubliJet® R** ink, you agree to be bound by the terms of this PLA. If you do not agree to the terms of this PLA, Sawgrass is unwilling to license the process of using the **SubliJet® R** ink to you. In such event, you may not use the **SubliJet® R** ink, and you should promptly contact your supplier for instructions on return of the unopened package.

The process of using the **SubliJet® R** ink is protected by U.S. and foreign patents. Sawgrass will provide a complete list of the relevant patents upon request. The use of the **SubliJet® R** ink to practice the patented process is permitted by this license.

GRANT OF LICENSE: This PLA grants you the following rights: You may install and use the SubliJet R ink packaged herewith in your Ricoh printer to practice the printing process described in U.S. Patent No. 5,488,907. The use of any ink, dye, or pigment to practice the Sawgrass Process, other than a **SubliJet® R** Ink purchased from Sawgrass or its authorized distributor accompanied by a PLA, is not a licensed use of the Sawgrass Process. No rights to use the Sawgrass Process, except those specified herein, are granted, and no rights to use any other process, product, software, or hardware developed or sold by Sawgrass are granted or implied hereby.

LIMITATIONS ON REVERSE ENGINEERING: You agree that you will not attempt to reverse engineer, reproduce, or reformulate the **SubliJet® R** ink.

PATENTS AND COPYRIGHTS: Sawgrass owns multiple U.S. and foreign patents which apply to the Sawgrass Process and/or the **SubliJet® R** ink or its use. All patents in and to the **SubliJet® R** ink and the method of using the **SubliJet® R** ink are owned by Sawgrass Technologies, Inc. You may not copy the printed materials accompanying the **SubliJet® R** ink. All rights not specifically granted under this PLA are reserved by Sawgrass Technologies, Inc.

Made In U.S.A.

CAUTION:

- For best printing results, use the ink within six months of purchase. Please refer to the individual ink bag/cartridge for the specific ink expiration date.
- Keep out of reach of children.
- Do not expose ink to temperatures above 100° F or below 40° F.
- Keep ink out of direct sunshine.

Sawgrass Technologies, Inc. agrees to replace any defective ink within a reasonable time, which shall be Sawgrass’ sole responsibility for errors or defects in these goods.

THERE ARE NO OTHER WARRANTIES, EXPRESSED OR IMPLIED, INCLUDING, BUT NOT LIMITED TO, ANY IMPLIED WARRANTY OF MERCHANTABILITY OR ANY IMPLIED WARRANTY OF FITNESS FOR A PARTICULAR PURPOSE. SAWGRASS SHALL NOT BE LIABLE FOR LOSS OF PROFIT OR OTHER ECONOMIC LOSS, OR FOR INDIRECT, SPECIAL, CONSEQUENTIAL OR OTHER SIMILAR DAMAGES.

The following Registered Trademarks, “SubliJet®R”, “PowerDriver™R”, “PowerDriverXG®”, “PowerDriver R1900XG®”, and “PowerDriverSupraXG®”, and the trademark ColorSure™ are all properties of, Sawgrass Technologies, Inc.

END-USER LICENSE AGREEMENT FOR SAWGRASS SOFTWARE - PowerDriver™R, PowerDriverXG®R, PowerDriverLite®, PowerDriver R1900XG®R, and PowerDriverSupraXG®R

IMPORTANT-READ CAREFULLY: This Sawgrass Technologies Inc. End-User License Agreement (“EULA”) is a legal agreement between you (either an individual or a single entity) and Sawgrass Technologies, Inc. for the Sawgrass software product identified above, which includes computer software and may include associated media, printed materials, and “online” or electronic documentation (“SOFTWARE PRODUCT”). By installing, copying, or otherwise using the SOFTWARE PRODUCT, you agree to be bound by the terms of this EULA. If you do not agree to the terms of this EULA, do not install or use the SOFTWARE PRODUCT.

Software PRODUCT LICENSE

Copyright laws and international copyright treaties, as well as other intellectual property laws and treaties protect the SOFTWARE PRODUCT. The SOFTWARE PRODUCT is licensed, not sold. The title to, and ownership of, this SOFTWARE PRODUCT remains with Sawgrass Technologies, Inc. (Sawgrass).

GRANT OF LICENSE. This EULA grants you the following rights:

- This license is provided to you for your use according to the terms hereof. You may install and use the SOFTWARE PRODUCT packaged herewith to practice the printing process described in U.S. Patent No. 5,488,907 (the “Sawgrass Process”). The use of any ink, dye or pigment to practice the Sawgrass Process, other than a SubliJet ink which is purchased from Sawgrass or its authorized distributor, is not a licensed use of the SOFTWARE PRODUCT. You agree not to use the SOFTWARE PRODUCT for any other purpose or in any process except as expressly permitted hereby.
- Not for Resale. You may not sell, or otherwise transfer for value, the SOFTWARE PRODUCT.
- No Reverse Engineering, Decompilation, Copying or Disassembly. You may not reverse engineer, decompile, copy or disassemble the SOFTWARE PRODUCT.
- No Rental. You may not rent, lease, or lend the SOFTWARE PRODUCT.
- Support Services. Sawgrass Technologies, Inc. may provide you with support services related to the SOFTWARE PRODUCT (“Support Services”). Use of Support Services is governed by the Sawgrass policies and programs described in the user manual, in “online” documentation, and/or in other Sawgrass provided materials. Any supplemental software code provided to you as part of the Support Services shall be considered part of the SOFTWARE PRODUCT and subject to the terms and conditions of this EULA. With respect to technical information you provide to Sawgrass as part of the Support Services, Sawgrass may use such information for its business purposes, including for product support and development. Sawgrass will not utilize such technical information in a form that personally identifies you.
- No Assignment or Sublicense. You may not assign or sublicense the rights granted hereby.
- Termination. Without prejudice to any other rights, Sawgrass may terminate this EULA if you fail to comply with the terms and conditions of this EULA. In the event of termination, you must destroy all copies of the SOFTWARE PRODUCT and all of its component parts.

COPYRIGHT. All title and copyrights in and to the SOFTWARE PRODUCT (including but not limited to any images, photographs, animations, video, audio, music, text, and “applets” incorporated into the SOFTWARE PRODUCT), the accompanying printed materials, and any copies of the SOFTWARE PRODUCT are owned by Sawgrass Technologies Inc. or its suppliers. Copyright laws and international treaty provisions protect the SOFTWARE PRODUCT. Therefore, you must treat the SOFTWARE PRODUCT like any copyrighted material, except that you may install the SOFTWARE PRODUCT on a computer for the uses permitted hereby. You may not copy the printed materials accompanying the SOFTWARE PRODUCT. You may not loan, rent, lease, or otherwise transfer the other medium to another, except as part of the permanent transfer (as provided above) of the SOFTWARE PRODUCT.

U.S. GOVERNMENT RESTRICTED RIGHTS. The SOFTWARE PRODUCT and documentation are provided with RESTRICTED RIGHTS. Use, duplication, or disclosure by the Government is subject to restrictions as set forth in subparagraph (c)(1)(ii) of the Rights in Technical Data and Computer Software clause at DFARS 252.227-7013 or subparagraphs (c)(1) and (2) of the Commercial Computer Software–Restricted Rights at 48 CFR 52.227-19, as applicable.

MISCELLANEOUS

- a. If you acquired this product in the United States, this EULA is governed by the laws of the State of South Carolina. In the event of any dispute arising under this license or from the use of the SOFTWARE PRODUCT, each party irrevocably agrees to the jurisdiction of the United States District Court for the District of South Carolina, Charleston Division.
- b. If you acquired this product in Canada, this EULA is governed by the laws of the Province of Ontario, Canada. In the event of any dispute arising under this license or from the use of the SOFTWARE PRODUCT, each party irrevocably agrees to the jurisdiction of the courts of the Province of Ontario and further agrees to commence any litigation which may arise hereunder in the courts located in the Judicial District of York, Province of Ontario. If this product was acquired outside the United States, then local law may apply.

LIMITED WARRANTY. Sawgrass warrants that (a) the SOFTWARE PRODUCT will perform substantially in accordance with the accompanying written materials for a period of thirty (30) days from the date of receipt, and (b) any Support Services provided by Sawgrass shall be substantially as described in applicable written materials provided to you by Sawgrass, and Sawgrass support engineers will make commercially reasonable efforts to solve any problem issues. Some states and jurisdictions do not allow limitations on duration of an implied warranty, so the above limitation may not apply to you. To the extent allowed by applicable law, implied warranties on the SOFTWARE PRODUCT, if any, are limited to thirty (30) days.

CUSTOMER REMEDIES. Sawgrass’ and its suppliers’ entire liability and your exclusive remedy shall be, at Sawgrass’ option, either (a) return of the price paid, if any, or (b) repair or replacement of the SOFTWARE PRODUCT that does not meet Sawgrass’ Limited Warranty and which is returned to Sawgrass with a copy of your receipt. This Limited Warranty is void if failure of the SOFTWARE PRODUCT has resulted from accident, abuse, or misapplication. Any replacement SOFTWARE PRODUCT will be warranted for the remainder of the original warranty period or thirty (30) days, whichever is longer. Outside the United States, neither these Remedies, nor any product support services offered by Sawgrass are available without proof of purchase from an authorized international source.

NO OTHER WARRANTIES. To the maximum extent permitted by applicable law, Sawgrass and its suppliers disclaim all other warranties and conditions, either express or implied, including, but not limited to, implied warranties of merchantability, fitness for a particular purpose, title, and non-infringement, with regard to the SOFTWARE PRODUCT, and the provision of or failure to provide Support Services. This Limited Warranty gives you specific legal rights. You may have others, which vary from state/jurisdiction to state/jurisdiction.

LIMITATION OF LIABILITY. To the maximum extent permitted by applicable law, in no event shall Sawgrass or its suppliers be liable for any special, incidental, indirect, or consequential damages whatsoever (including, without limitation, damages for loss of business profits, business interruption, loss of business information, or any other pecuniary loss) arising out of the use of or inability to use the SOFTWARE PRODUCT or the provision of or failure to provide Support Services, even if Sawgrass has been advised of the possibility of such damages. In any case, Sawgrass' entire liability under any provision of this EULA shall be limited to U.S. \$5.00. Because some states and jurisdictions do not allow the exclusion or limitation of liability, the above limitation may not apply to you.

Table of Contents

Agreements and Warranties

SubliJet; Process Licence Agreement	ii
End User Licence Agreement	iii
Miscellaneous	iv

Ricoh GX7000 Printer Setup

Introduction.....	2
About This Document.....	3
Ink Cartridge Setup.....	4
Adjusting the Head & Paper Alignment Position	5
User Guide PowerDriver™ R for the Ricoh GX7000.....	7
Introduction	8
PowerDriver™ R Ricoh GX7000 System Requirements	8
PowerDriver™ R Quick Start Installation Instructions	9
PowerDriver™ R Setup	11
Using PowerDriver™ R for the Ricoh GX7000	16
PowerDriver™ R Printing Preferences Overview	21
Appendix A: Over-riding Application Color Management.....	24
Appendix B: Using ColorSure™ & Custom Palette in PowerDriver™ R	29
Selecting Paper	35
Heat Transfer Instructions	35
Tips for Successful Sublimation.....	36
Supplies & Equipment	38
Storage	38
Troubleshooting.....	39
Technical Support	41
Project Sublimation.....	41

Introduction

Congratulations on your purchase of the **SubliJet®** Ink System with **SubliJet® R** digital transfer inks. This system for the Ricoh GX7000 is the latest advancement from Sawgrass Technologies, Inc., a leader in the development of digitally driven color transfer technologies and related products.

Your SubliJet Ink System includes: **SubliJet® R** inks and **PowerDriver™ R** Ricoh GX7000 color matching software. This revolutionary, comprehensive system takes sublimation to the professional level, allowing users to create perfect transfers with minimal effort. With true six-color printing, the **SubliJet® R** System increases color gamut, creates noticeably smoother gradient transitions, captures finer detail and adds color depth.

With this system, your printed images can be transferred onto any product designed to accept sublimation dyes including: ceramic, metal, tiles, mylar, polyester fabric, performance wear, and UniSub®, resulting in an attractive, durable product. Your imagination is the limit for producing brilliant, near photo-quality images on caps, clipboards, clocks, mugs, mouse pads, plaques, puzzles, synthetic t-shirts, and more. **SubliJet® R** Ink is ideal for markets that personalize, customize or create short-run output.

This document contains information for using **SubliJet® R** inks and helpful tips are also provided for getting the best results from your transfers. The information provided pertains only to the use of **SubliJet® R** in your Ricoh GX7000 printer. If you have questions about the operation of your RICOH printer, refer to the Ricoh GX7000 Printer User's Guide.

Technical support is available from your Authorized SubliJet reseller or directly from Sawgrass Technologies, Inc. See the section entitled Technical Support for additional information.

We at Sawgrass strive to provide you with the tools to make the sublimation process easy to learn and simple to master. We hope you will find that the tools we have developed will make your years in the sublimation business fun and profitable. Please feel free to contact us with your feedback about our products. For additional information on our other products, visit our web site at www.sawgrassink.com.

Thank you and enjoy your **SubliJet®** Ink System.

About this Document

This document contains descriptions and procedures for using **SubliJet® R** inks, along with additional information for getting the best results from your transfers.

The documentation provided pertains only to the use of **SubliJet® R** inks in your Ricoh GX7000 ink jet printer. To assist you in the overall setup process, references are made back to the Ricoh GX7000 Printer Users Guide for instructions.

To help point out important information, specific instructions, and helpful tips look for the following symbols:



Danger

Indicates a Hazard that could seriously Compromise the use of the machine, and / or the physical safety of the operator.



Warning

Indicates Must Do Items, significant warnings, and Important Guidelines. These must be followed to prevent damage to your printer.

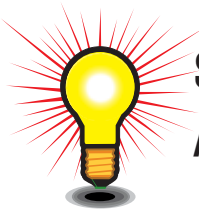

**Suggestion
/Remark**

Indicates Suggestions to optimize the operation of your machine, or the printing process.



Tip

Indicates useful “Tips”, Materials, Practices, and / or Observances that will have a beneficial impact on either Printing and/or Sublimation.

Ink Cartridge Setup for the Ricoh GX7000



CAUTION:

DO NOT INSTALL RICOH OEM INK BEFORE INSTALLING SUBLIJET R INK. Do not power ON the printer before installing the cartridges.

1. Remove the cartridges from their packaging.
2. Open the right front cover on the printer

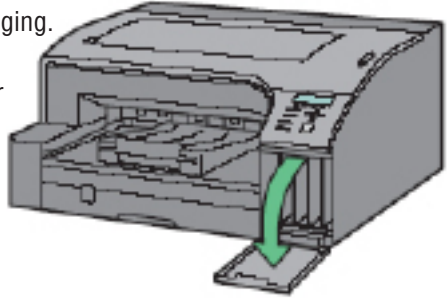

3. Insert the **SubliJet®R** cartridges in the indicated order. Press each cartridge body until it engages securely.



Do not shake or agitate ink carts before or after installation.

**Cartridge Order:
Black, Cyan, Magenta, Yellow**

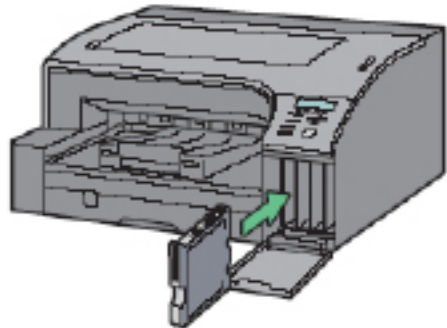

4. Once all cartridges are in place, close the cartridge cover.
5. Next, the Ricoh printer driver must be installed and the printer head position and paper alignment position must be set.

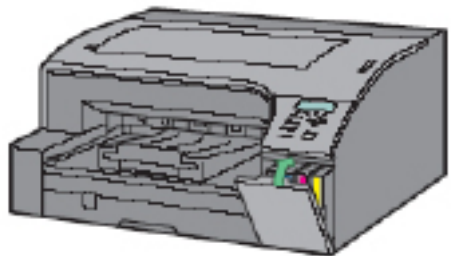

DO NOT TURN ON THE POWER FOR THE PRINTER UNTIL YOU ARE TOLD TO DO SO.

Quick Start Installation - Ricoh OEM Driver

1. Unpack and setup printer as described in the setup instructions. Have the printer plugged into a **Power Outlet** but not turned on.
2. Install the Ricoh **CD** in the **CD-ROM** drive.
3. Select a language for the interface & click **OK**.
4. Click **Quick Install** with **USB**, and then click next.
5. Follow the onscreen instructions to complete the driver installation.
6. Once the driver is installed, the printer firmware must be updated to allow maximum output on the printer. To do this, go to the **Ricoh** website at www.ricoh-usa.com.
7. Go to the **Downloads** section of the website and click on the **Download Ricoh Drivers & Software** option.
8. If you agree to the **Software License** agreement click **OK**.
9. Under the **Product Drivers** and printers section, search for the **B&W/Color/Gel** printer option and use the drop down list to select **Aficio GX7000** and click **Go**.
10. Click on the **Firmware** link and the page will redirect to the firmware downloads.
11. Select the **Firmware Update Version 1.13** download option. Choose **Save > File** and save the file to the hard drive.
12. Once the file has finished downloading, find the downloaded file on the hard drive and run the executable.
13. Follow the onscreen instructions to complete the installation. Once completed, you can install **PowerDriver R**.

Adjusting the Ricoh Printer Head Position & Paper Alignment Position

1. Open the **Printers/Faxes** control panel window.
2. Right click on the **Gelsprinter GX7000** printer option & select **Printing Preferences**.
3. At the top of the dialog window, select the **Maintenance** tab.
4. There are two options that will be used for adjusting the Ricoh printer for optimum output – the **Adjust Paper Feed** option & the **Adjust Print-Head Positions** option.
5. Start by selecting the **Adjust Paper Feed** option.

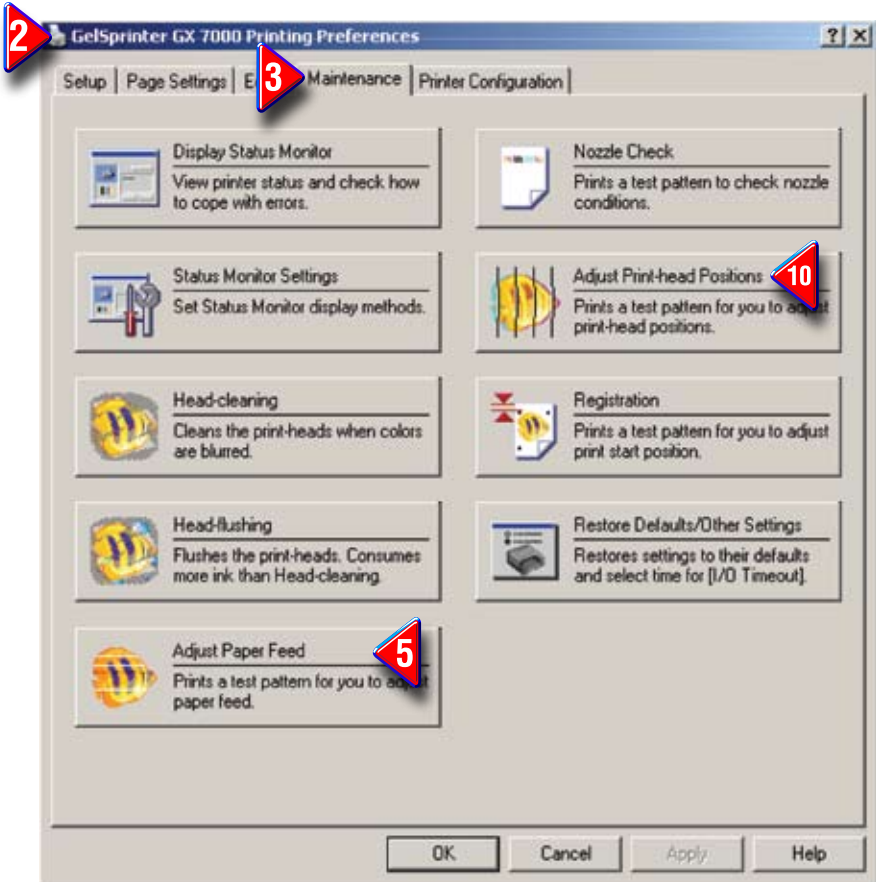

Figure 1

6. Follow the screen shots to print out a test sheet.
7. Once the test sheet has printed, review the page to determine the optimum level for your printer.

8. To determine which value is optimum, look for the number that appears on the left of the lightest gray square with straight horizontal lines on both sides. (**Figure 1**) When horizontal lines beside the lightest gray square are broken, select the optimal adjustment value by referring to the lines broken in the opposite direction. (**Figure 2**)

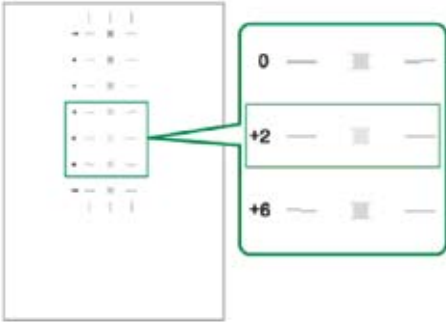

Figure 1

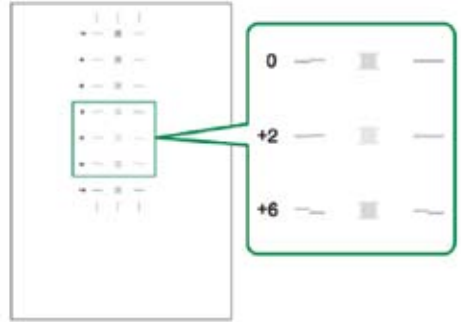

Figure 2

9. Once the optimum value is decided, go back to the printer dialog window & type in the value. Hit **Next** to complete the change.
10. Next select the **Adjust Print-Head Positions** option.
11. Follow the screen shots to print out a test sheet. Select the **Quality Priority/Speed Priority** option for printing the test pattern.
12. Once the test sheet has printed, review the page to determine the optimum level for your printer.

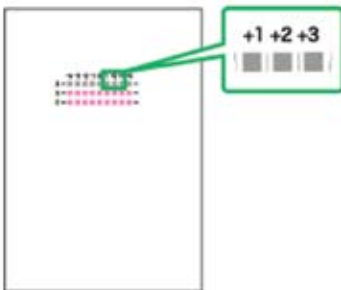

Figure 3

13. To determine which value is optimum, look for the column number that appears above the lightest gray square with straight vertical lines on both sides for each row.
14. Once the optimum value is decided, go back to the **Printer Dialog Window** & type in the value. Hit **Next** to complete the change.

15. Follow the instructions on the next pages to install the **PowerDriver R** software. Once completed, run a test print to see if the settings are acceptable. If banding is extreme, start from step one and adjust the settings again until the optimum print value is found.

Next is the loading of the software. You will need to load the PowerDriver R Ricoh GX7000. Please follow the instructions in the PowerDriver section.

POWERDRIVER[®] **R** RICOH **GX7000**

SUBLIJET R COLOR MANAGEMENT DRIVER FOR THE RICOH GX7000 - 4 COLOR

For the **Ricoh GX7000 Printer**

NOT FOR RESALE
For Distribution With
SubliJet[®] R Ink ONLY

Revision 1.0

Sawgrass Technologies, Inc. ~ www.sawgrassink.com

Introduction

Using PowerDriver R Ricoh GX7000

SubliJet digital printing systems are comprised of a few key tools to ensure high quality output each time you print with SubliJet R Inks. PowerDriver R Ricoh GX7000 color management software is one of those tools.

PowerDriver R Ricoh GX7000 color management software is a professional grade color management program that provides SubliJet users with the necessary tools to ensure colors print right the first time. PowerDriver R Ricoh GX7000 software is available for all major Windows based operating systems. To be sure of system compatibility, please visit us at <http://www.sawgrassink.com/v.php?pg=296>.

PowerDriver R Ricoh GX7000 software and profiles are intended to give you simple, easy to use color management tools to take the guesswork out of sublimation printing. With the click of your mouse you can automatically optimize colors for popular substrates like Unisub™, polyester performance apparel, ceramics, metal, and many others. This is a valuable tool that saves you time, money, and limits your need for costly sampling trying to get the job right.

PowerDriver R Ricoh GX7000 also comes standard with the ColorSure Palette matching system. The ColorSure Palette is absolutely the best way to achieve spot color accuracy in sublimation transfers. The palette allows you to fill solid portions of artwork with a color from the palette, thus knowing how it will look once transferred. With the help of the ColorSure Palette, you will successfully choose the correct colors, whether you are matching colors for a custom order or selecting colors for new artwork.

PowerDriver R Ricoh GX7000 is the most advanced color management software available on the market for digital transfer systems. This software was developed specifically for desktop sublimation systems; you will discover enhanced functionality as well as a new level of color output when PowerDriver R Ricoh GX7000 is used. Used in conjunction with SubliJet digital transfer inks you and your customers will truly experience the next generation in digital color!

PowerDriver R Ricoh GX7000 System Requirements

Minimum Hardware:

Pentium 4 – 3.0GHz or Athlon XP 2000+ Processor
512 MB System Memory

Recommended Hardware:

Pentium 4 – 3.0GHz or Athlon XP 2500+ Processor
1 GB System Memory

Required Operating System:

Microsoft Windows XP & Vista (32 Bit only)

Setup Instructions

Product Overview

PowerDriver is color management software that has been written as a **Windows** printer driver. It is designed to work with **Ricoh Ink-Jet Printers** and **Sawgrass** sublimation ink. The installation program will automatically install **Sawgrass** color management software, the **Sawgrass PowerDriver R Ricoh GX7000** printer driver software, and **ColorSure** tools and utilities. For instructions on installing **PowerDriver R Ricoh GX7000** see the **PowerDriver R Ricoh GX7000 Step by Step Installation** documentation starting below.



CAUTION:

The Ricoh OEM Driver must be installed and all updates to both the driver & firmware must be completed *before* installing PowerDriver R

Quick Start Installation - PowerDriver™ R

1. Insert the PowerDriver CD into the CD ROM drive on the computer and install the PowerDriver™ R for the Ricoh GX7000.
2. Follow the on-screen instructions to complete installation.

PowerDriver™ R Ricoh GX7000 Setup

To get started printing as soon as possible, these are the Sawgrass recommended steps to perform while setting up your sublimation printer driver software.

Step by Step Installation

1. Insert the **PowerDriver™ R Ricoh GX7000 CD** into your **CD-ROM** drive. The installation program should run automatically. (If the program does not automatically run, click **Start > Run**. Browse to your **CD-ROM** drive and click on **Setup**).
2. The **Welcome Screen** is displayed next. Click **Next** to proceed.



Figure 1

3. The **License Agreement** is displayed next. Select the appropriate choice for acceptance of the **License Agreement** to continue.



Figure 2

4. The installation program will now open the **Choose Components Option**. Ensure that the **Add Printer, Register & Install** application palette boxes are checked and click “**Next.**”



Figure 3

5. The **Product Registration Screen** will appear and ask if you would like to **Register Now**. Click “**Yes**” In the **PowerDriver R Ricoh GX7000 Registration Screen**, you will use your **Product ID** to obtain a **Registration Code**. You will need a separate **Code** for every machine on which **PowerDriver R Ricoh GX7000** is installed. In **Figure 5**, Click on the button labeled “**Click Here to Obtain Registration Code**”.



Figure 4

To obtain your registration code you may do so in one of the following ways:

- a) Register **On-line** and receive your **Registration Code** via **E-mail**.
- b) Call **Sawgrass Technologies, Inc.** directly **(888) 253-1679** and obtain your **Code** over the **Phone**.
- c) Send a **Fax** and receive your **Registration Code** by **Fax**.



Figure 5

6. If you choose to register on-line. The Product Registration Web Page now opens. Complete the requested information on the web page and click Continue.

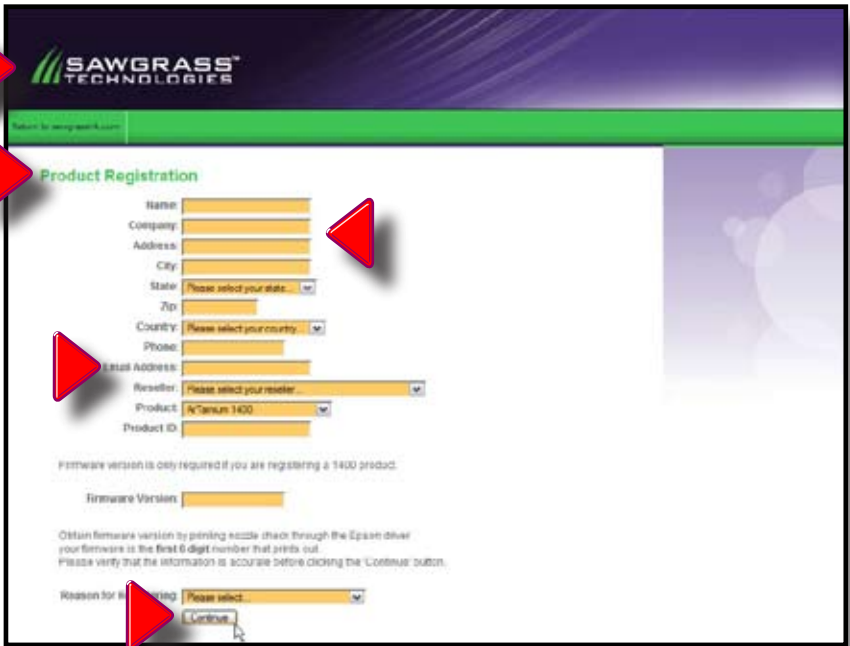

Figure 5

7. Once the website registration information has been completed, a “Thank You” message will appear. An e-mail will be sent to the address you specified. Retrieve the registration e-mail from your in-box and make note of the **Registration Code** given. Toggle back to the **PowerDriver R Registration Screen** and enter this number in the “**Registration Code**” Box at the bottom of the “**Power Driver R Ricoh GX7000 Registration**” screen shot shown on the previous page. Click “**Apply Code**”. Screen will appear indicating that you have successfully registered your driver software. Click - to continue the installation process.



Figure 6



If you decide to register later, and continue using the driver during the initial five day **Pre-registration Grace Period**, your system will generate a **Pop-Up Screen** stating you need to register. Go to the **Printing Preferences** page of the **PowerDriver R Ricoh GX7000 Driver** and click on **“Register.”**

8. The **Color Management Check Screen** will appear. Click the **“Continue” Button** on the left side of the screen after you have disabled the **Color Management** feature of the **Corel** or **Adobe Graphic Software**. Click **“Show Me How”** if you need instructions on how to accomplish this **Sawgrass Technologies, Inc. ColorSure Color Palettes** for use with **Corel®** and **Adobe®**, (See **Appendix A**). (Check the **ColorSure** section, (**Page 29**) for information on how to use **ColorSure** to get perfect spot colors). If **Setup** detects either of these applications on your system, the **Palette Files** will be placed in the appropriate folder indicated in the **Destination Folder Box**. Click **“Continue”** to proceed with the installation.



Figure 8



Note: In order to use **PowerDriver Color Management Software**, the color management features in either **Corel®** or **Adobe® Programs** must be disabled. Please see the instructions in **Appendix A**, or click on the **“Show Me How”** Button on the **“Color Management Check”** Screen shown in the next step.

9. The **Powerdriver R** installation program will show the progress of the installation in a status monitor.

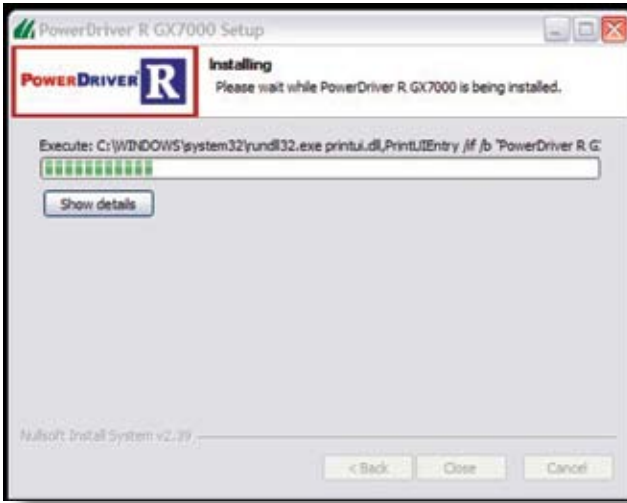

Figure 9



Note: Cancel any ‘**Found New Hardware**’ wizards that may start during this process, do **NOT cancel** any file copy processes.

10. If you see the “**Hardware Installation**” Screen below, click “**Continue Anyway**” to proceed with the Installation.



Figure 10

11. Once the installation has completed, the “**Installation Complete**” Screen will display. Click “**Close**” to end the installation. Congratulations, you are now ready to experience creativity on a whole new level.



Figure 11

Using PowerDriver Ricoh GX7000 in Windows XP and Vista

PowerDriver R Ricoh GX7000 is simple to use. Whenever you have **SubliJet R** inks in your printer, you should print using **PowerDriver R**. Do not print to your **Ricoh Printer** with the **Ricoh Printer Driver** since printing with the **OEM Driver** will not give you the benefit of color management.

Quick Start Example (CorelDRAW)

1. Open/Create an image in **CorelDRAW**. Select **Print** from the **File Menu**.



Figure 1

2. Select **“PowerDriver R GX7000”**. Use the **Properties Button** to access the **“PowerDriver Document Properties” Screen**. so that you can set the **Size**, **Substrate**, **Color**, and **Resolution** that your image requires. Click **“OK”**.

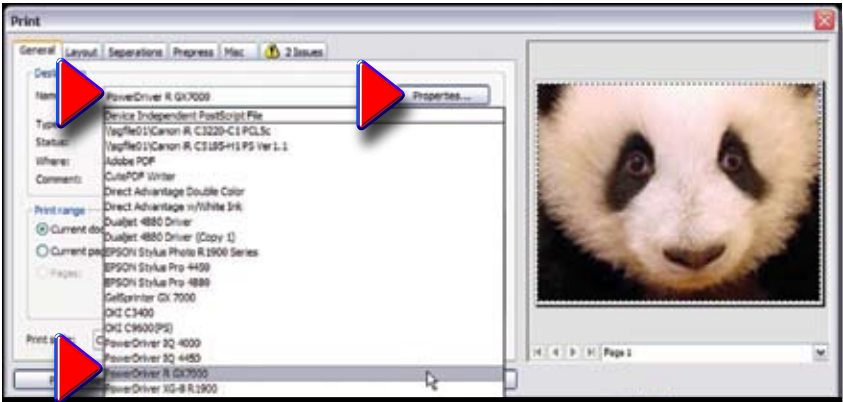

Figure 2

3. The **“PowerDriver Document Properties” Screen** allows you to set the **Paper Size**, **Paper Type**, **Substrate**, **Color**, and **Resolution** that your image requires. Click **“OK”**. This returns you to the **CoreIDRAW “Print” Screen**. Click **Print** to proceed.

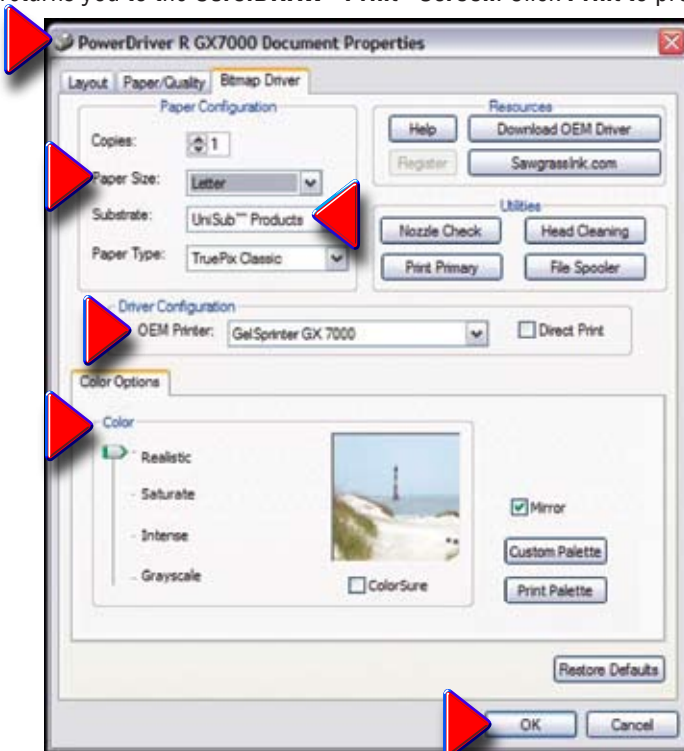

Figure 3

Setting PowerDriver R Document Properties

To configure **PowerDriver R GX7000** for the correct substrate, you must display it's **Document Properties**. There are two ways to display the **Document Properties**:

From the Windows Desktop:

1. Click on **Start**> **Printers and Faxes**.



Figure 1

2. Right-click on your **PowerDriver R GX7000** (Pointer 1) and select **Properties** (Pointer 2) from the **Pop-Up Menu**.

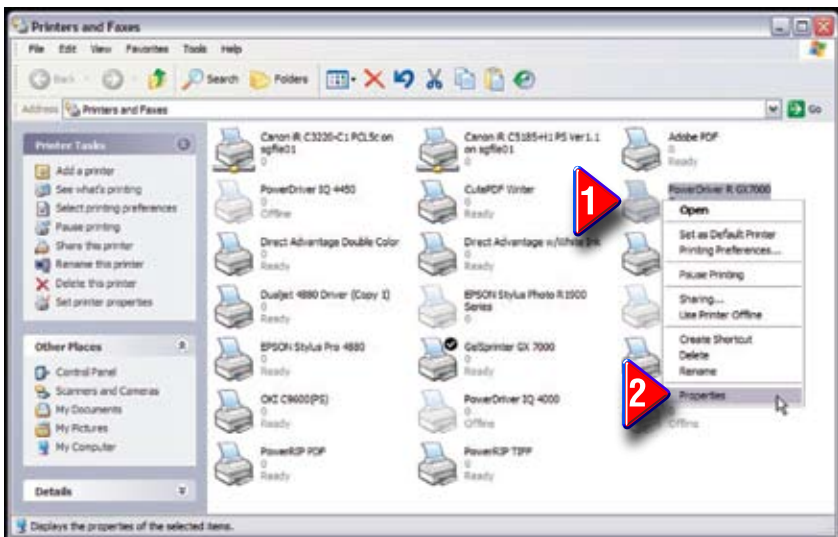

Figure 2

- This takes you to the **“PowerDriver R GX7000 Properties”** Screen shown in **Figure 3** below.

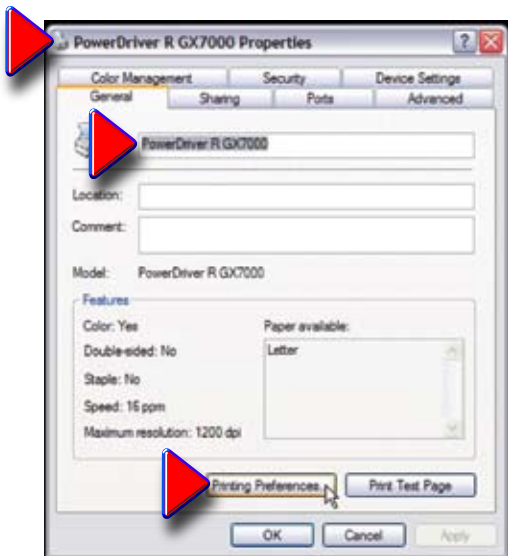

Figure 3

- Click on the **“Printing Preferences”** Button, bringing you to the **“PowerDriver R GX7000 Printing Preferences”** Screen (**Figure 4**). After setting the **Paper Size**, **PaperType**, **Number of copies**, **Substrate**, **OEM printer**, and **Color** that your image requires, Click **“Apply”**, then **“Ok”**, to return to the **“Properties”** Screen. Click **“Ok”** to return to the **“Printers”** List.

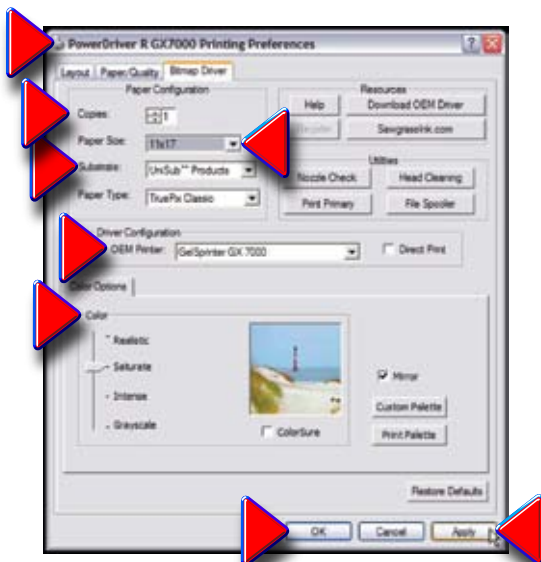

Figure 4

From an Application:

1. Select **File**, > **Print Setup**.



2. From the **“Print Setup”** Screen, choose the **PowerDriver R Ricoh GX7000** from the scroll-down list. Click the **Properties Button**.

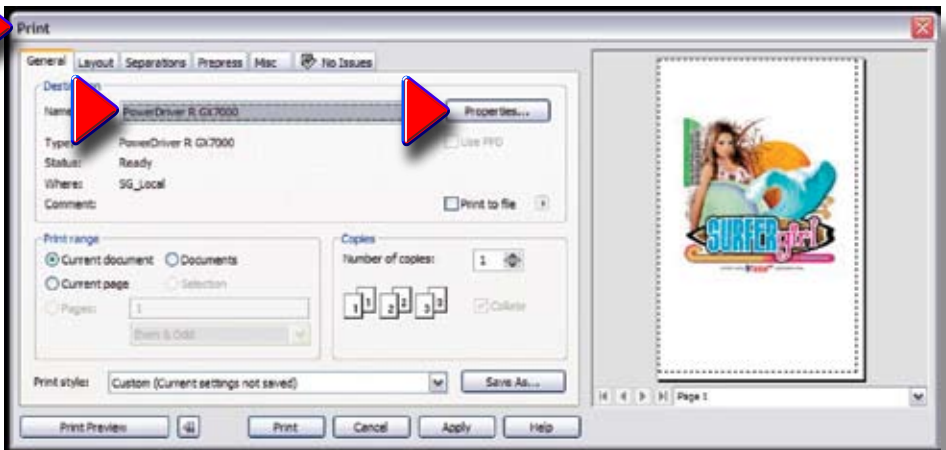

Figure 2

PowerDriver R Ricoh GX7000 Printing Preferences Overview

The following figure shows the printer properties for a **Registered** version of **PowerDriver R Ricoh GX7000 Printer Properties**.

There are three main property groups;

1. **Configuration** – Set Paper, Transfer Substrate, Copy Count and OEM Printer.
2. **Color Options** – Color Management Control Options & Print Resolution.
3. **Resources**– Utilities, (for printer maintenance), online Help, & Product Registration.



Group 1 – Configuration

Paper Size – From the drop down list, select the paper size you wish to use.

Substrate – From the drop down list, select the type of material to which you will be transferring your printed image. It is important to choose the correct substrate. PowerDriver's color management is optimized for each different substrate.

Copies – Sets the copy count for the number of prints to be made.

OEM – Sets the OEM Printer Configuration for the printer used.

Group 2 - Color Options

Overview

This tab gives you access to all of the color management controls available in **PowerDriver R**. Utilizing the power of the **Ricoh GX7000 Driver** technology, the **PowerDriver** interprets bitmap and vector elements in a similar manner.

Vector and Bitmap Explanation

Bitmaps are a grid of pixels. **Bitmaps** come from digital cameras, scanners, and photo CDs. **Bitmaps** can also be created in applications like **Corel PhotoPaint** or **Adobe PhotoShop**. Bitmaps have file extensions like **GIF, JPG, BMP, and TIF**. **Vector** components consist of shapes, curves, lines, and text. They are created in programs such as **CorelDraw** and **Adobe Illustrator**. Higher end programs like **CorelDraw** can combine **Vector** and **Bitmaps** into a single image. **PowerDriver** will color correct all bitmap files and vector components as bitmap images.

Bitmap Options

- **No Color Management** – To unleash the power of the **PowerDriver Software**, the color management will need to be turned off (over-ridden) in the **Graphic Software**. (Instructions on how to do this are provided in **Appendix A, Pages 20 thru 24**, covering **Corel & Adobe Applications**.) This facilitates optimum color management of **SubliJet inks**. If you select the “**No Color Management**” option, all color management will have to be accomplished using the **Graphic Design Software**, i. e. the **Corel &/or the Adobe Applications**.
- **Saturated** - Intended for use with clip art, text and other vector based graphics or images that contain saturated colors.
- **Realistic** - Intended for use with photographs or images that contain prominent skin tones or highlights.
- **Intense** - Select this setting to get the most intense color output possible.
- **Grayscale** - This setting is intended for use with grayscale images.
- **ColorSure Checkbox** - ColorSure is used to replace specific colors in your image with a spot color chosen from the ColorSure palette. This resulting spot color enhancement is not affected by color setting. A ColorSure spot color will ALWAYS print the same. (Please see Appendix B, for an overview of ColorSure.)

ColorSure Options

- **Print Palette Button** – Prints the **ColorSure Palette** for the selected substrate. **ColorSure** is a tool for reproducing exact spot colors. The two main components are: **1) The Transferred Palette**, and **2) The CorelDraw, Corel PhotoPaint, and Adobe swatches**. For a complete description on how to use **ColorSure** to get perfect spot colors, see **Appendix B**.
- **Custom Palette Button** – This button launches the **Custom Palette Utility**, which enables you to add, edit, import, and export custom colors to the **ColorSure**

Palette. If you need to precisely match a specific color, the **Color Finder Tool** makes this a breeze. For a complete description on how to use the **Custom Palette**, see **Appendix B**.

Output Options

- **Mirror** – When you transfer an image, the result will be “flipped” when compared to the printed image. In order for your transfers to come out correctly, you must “flip”, or mirror the image before transferring.

Group 3 – Resources

- **Nozzle Check Utility** – Click this button to print a nozzle check pattern. If any of the nozzle check patterns are incomplete, then perform a printhead cleaning cycle. Individual channels maybe cleaned using this utility.
- **Head Cleaning** - Performs a printer head cleaning, after which a **Print Nozzle Check** should be performed to verify that the heads are completely cleaned. Repeat the **Head Cleaning** until a complete nozzle check pattern is produced.
- **Help** – This will display a help dialog box for an easy overview of the **PowerDriver R GX7000 Driver** functions and settings. Also contains a link to the **Sawgrass Technologies Website**.
- **Register** – If the **PowerDriver R GX7000** product has not been registered, click this button for instructions on how to register the product and unlock all the features.
- **Sawgrassink.com** – Links directly to the **Sawgrass Technologies Website** for additional resources.
- **Print Primary** – Use this function to print a page of the primary **R Ink Colors** (Cyan, Magenta, Yellow and Black).

Appendices

Appendix A: Over-riding Application Color Management

PowerDriver provides a complete color management solution for your **SubliJet** printing. It is extremely important that you turn off any color matching features associated with your design software. An explanation of how to disable print-time color management in several popular design packages follows:

CorelDraw™ versions X4, X3, 12, 11, & 10

- Create a new graphic.
- From the main menu choose **Tools > Color Management**. In the **Color Management Window**, set the **Style Option** to **Color Management Off**.

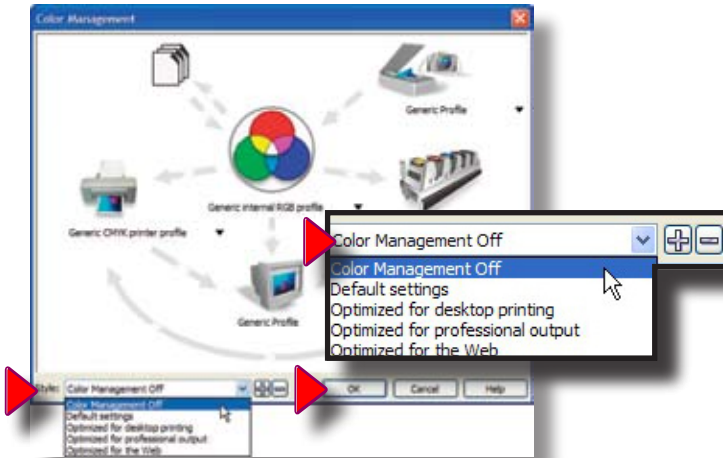
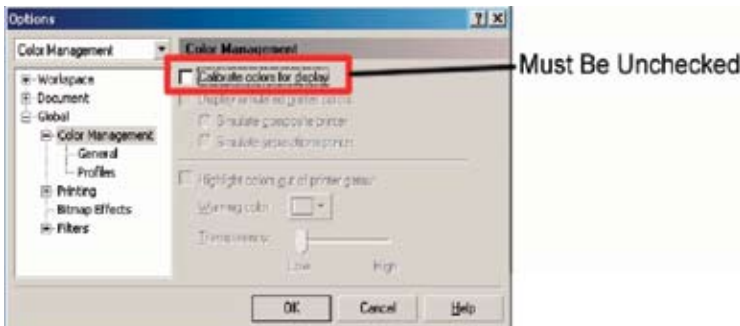

Figure 1

CorelDraw™ version 9

- Create a new graphic.
- From the **Main Menu** choose **Tools > Color Management**. The **Color Management Dialog Box** is displayed.
- In the **Color Management Window**, **UNCHECK** the “**Calibrate Colors for Display**” **Box**.



Adobe Photoshop CS3, CS2, CS, Photoshop 7 & 6.

Color Setup

From the **Main Menu**, choose **Edit, > Color Settings**. In the **Color Settings Dialog Box**, turn all **Color Management Policies** to “Off”. (See below.) Mark the box “**Ask When Opening**” next to “**Profile Mismatches**”.

Please Note:

Screen shown is from **CS3**. Other screens will appear with **slight** differences, however the settings remain the same throughout.

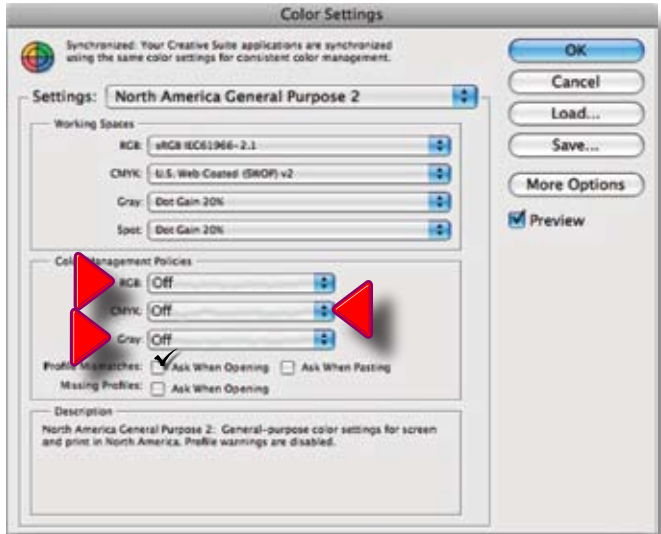

To Print; Adobe CS3:

Select **File, > Print**. On the print dialog page, set the options as follows:

- Upper Right Hand **Menu** to “**Color Management**”
- Choose “**Document**” by clicking the radio button.

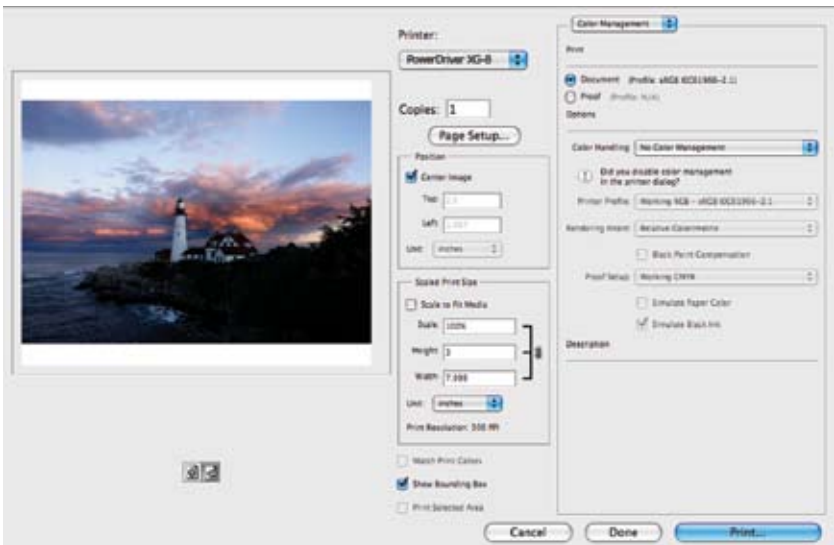

To Print; Adobe CS2,

Always select **File, > Print with Preview**. On the print dialog page, set the options as described in the following a thru d:

- a. Click on **“More Options”**.



- b. Choose **Color Management** in the drop-down menu.
- c. Choose **“Document”** by clicking the radio button.
- d. Under **“Options > Color Handling”** choose **“No Color Management”**.

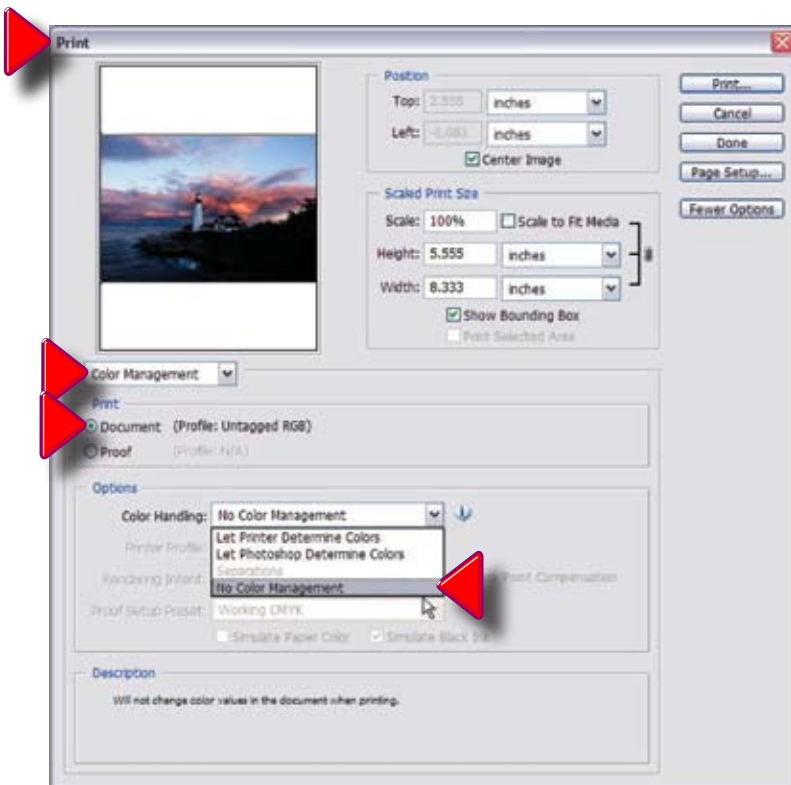

To Print; CS and Photoshop 7:

Always select **File**, > **Print with Preview**. On the print dialog page, set the options as described in the following a thru d:

- Click on **“More Options”**.
- Choose **Color Management** in the drop-down menu.
- Choose **“Document”** by clicking the radio button.
- Choose **Same as Source** for **Print Space**.

From the **Color Management** drop option list, make sure that **Source** is set to **“Document”** and **Print Space** is set to **“Same As Source”**.

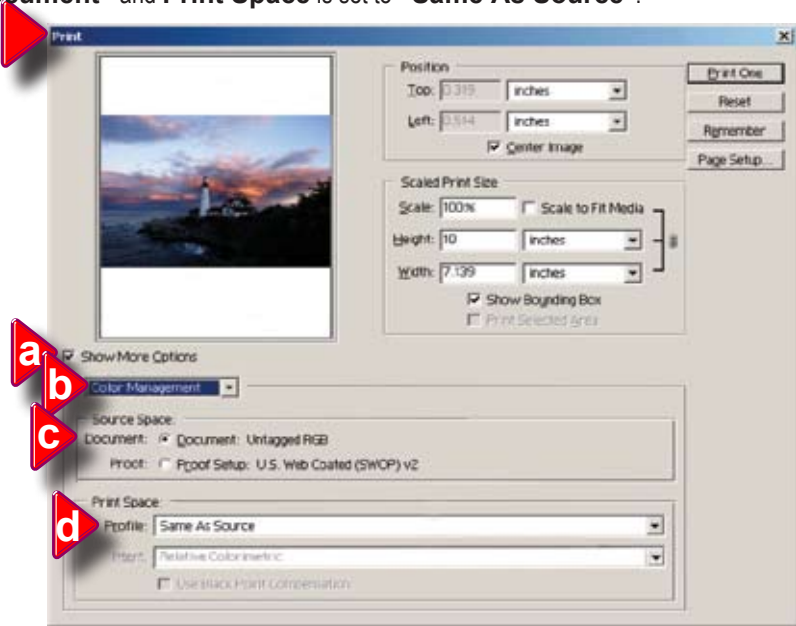

Adobe Photoshop Elements 5.0/4.0/3.0:

Select **Edit** and then **Color Settings** from the top drop down **Menu Bar**. Select **No Color Management**. Click **Ok**.

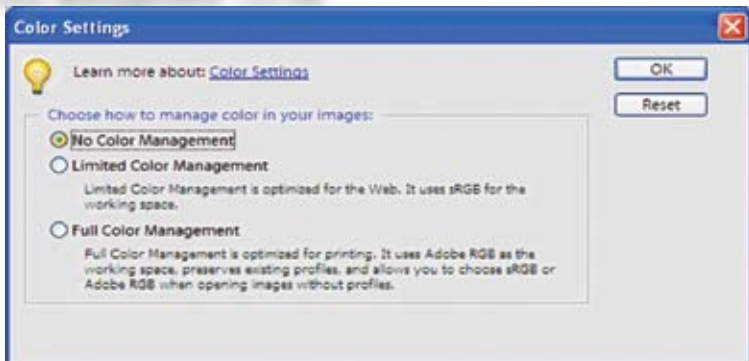

To Print RGB Graphics

Click **File**, > **Print**, then set the **Range, Print Quality, & Copies**.

Fill in radio button **“Document: Intagged RGB”**.

In **“Print Space”**, **“Profile”** should read: **“Same As Source”**.

Press **“OK”**.

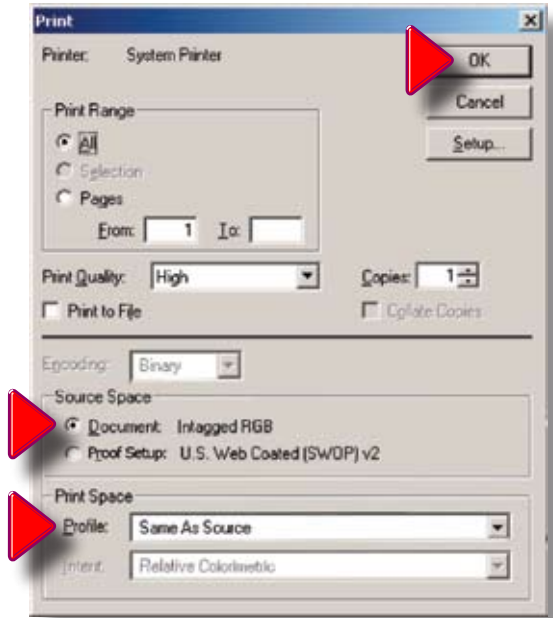

To Print CMYK Graphics

Click **File**, > **Print**, then set the **Range, Print Quality, & Copies**.

Fill in radio button **“Document: Intagged CMYK”**.

In **“Print Space”**, **“Profile”** should read: **“Printer Color Management”**.

Press **“OK”**.

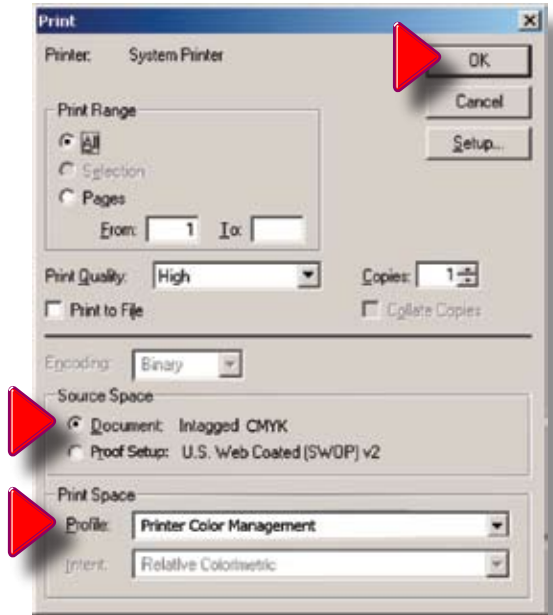

Appendix B: Using ColorSure™ and Custom Palette in PowerDriver®

I. Introduction

ColorSure is a method for reproducing exact spot colors. There are four main components of the **ColorSure System**: **1.)** The transferred palette; **2.) Color Finder**; **3.) Custom Palette**; and **4.)** The **CorelDRAW** and **Adobe** application palettes / swatches.

- 1. ColorSure Palette:** This is your main color palette that includes commonly used colors.
- 2. Color Finder:** If a color you need is not on the **ColorSure Palette**, the **Color Finder** tool allows you to locate the exact custom color you are looking for.
- 3. Custom Palette:** With the **Custom Palette** feature, you can add new custom colors to the existing **ColorSure Palette** mentioned in step 1.
- 4. Application Palettes:** You can add your **Color Finder** colors to an existing application palette, or you can add multiple custom colors to new, custom palette files (*.cpl, *.acl, etc.).

II. Printing the ColorSure Palette



The first step you will want to take is to print and transfer your **ColorSure Palette** to the various substrates you will be using. Most likely you will have customers who desire precise colors. Having your **ColorSure Palette** available allows the customer choose the color from the palette that is the closest match to what they want, and this gives you a starting point for finding the exact custom color that will match your customer's needs.

To print the ColorSure palette, follow the steps below:

- Click **'Start'** and navigate to the **'Printers and Faxes'** folder. Right-click on your **PowerDriver** icon and select **'Printing Preferences'** from the menu. You may also open **PowerDriver** from within an **Adobe** or **Corel** program by going to **File, Print**, and choosing the **PowerDriver** Printer from the pull-down menu. Click **Properties** to open **PowerDriver**.
- Choose the paper size you will be printing the palette to (**Letter, Legal, etc.**)
- Choose the substrate that you will be transferring the palette to.
- Select the speed / resolution of the palette – **High Speed** or **High Quality**.
- Be sure to check the box to mirror your print, click **'Print Palette,'** and then transfer the palette to the previously selected substrate.
- You now have a visual representation of how the **ColorSure Palette** colors will appear on that particular substrate.

III. Designing Your Artwork

By picking colors from the **ColorSure Palette**, you will be able to consistently reproduce colors in a reliable manner. To assist you in designing your artwork, **PowerDriver** installs three palettes: two for **Adobe** products and one for **Corel** products. These colors match the palette that is printed from within **PowerDriver**.

- To open the **ColorSure Palette** in **Corel 9,10, 11, 12, X3, or X4** choose: **Window| Color Palette| Open Palette**. Select the file “**ColorSure Palette Corel.**”
- To open the **ColorSure Palette** in **Illustrator**, choose **Window | Swatch Libraries | Other Library**. Navigate to where it was installed when you installed **PowerDriver: C:\Program Files\Sawgrass\PowerDriver\Adobe Illustrator** and hit **Open**. *For easier access to the **Palette**, **File-Copy** it from this [above] path to **Illustrator10\Presets\Swatches** and it will show up in your pull-down list directly under the **Swatch Libraries Menu**. Other versions of **Illustrator** will have similar steps.*
- To open the **ColorSure Palette** in **Adobe PhotoShop**, choose the **Swatches Palette**, click the option arrow on the palette, choose **Replace Swatches** and pick the “ColorSure PDIQXGv1.aco” file.

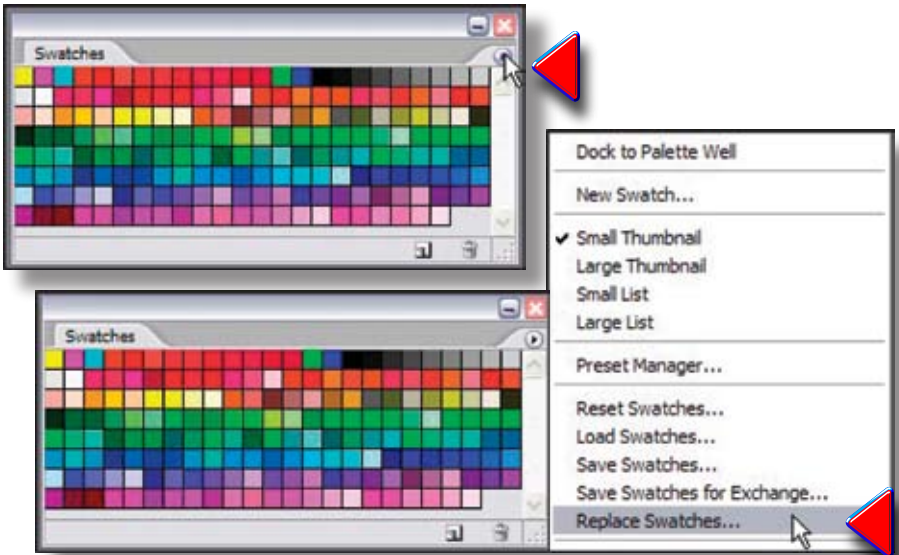

HINT

After you have the **ColorSure Palette** loaded into **CorelDraw**, move the cursor over each color. As the cursor hovers over each different color, the **ColorSure Name** is displayed in the status area below each color.

IV. Using Color Finder

After printing and transferring the **ColorSure Palette**, you see that you have an array of colors to work with. There will be times, however, when the color you need is not included in the **ColorSure Palette**. This is where the **Color Finder Tool** comes in handy.

The **Color Finder Tool** allows you to start with a specific color (e.g. navy blue) and find similar colors in the same family by adding and subtracting up to three colors (**RGB**) called **'Step Colors.'** For example, starting with navy blue with an **RGB** value of **6,6,85** and choosing two step colors (e.g. blue and red) would expand the original navy blue in four directions (more blue, less blue, more red, and less red). This expanded color chart – specific to a particular substrate and printing speed – prints directly to your printer.

How to use Color Finder:

- Open the **PowerDriver** window as instructed in **"Printing the ColorSure Palette"** outlined in **Section II.**
- At the bottom of the window, click the **Custom Palette Button**; this will open the **Custom Palette Utility** window. (**Figure 1**)
- First, make sure you select **PowerDriverIQ**, then your desired **Substrate & Output. (High Speed or High Quality)** This activates the **"PowerDriver Custom Palette Utility" Screen. (Figure 2)**
- In the **"Color Finder" Section**, at the right, click on the **"Start Color Chooser"** button and select your desired starting color from the matrix. If you do not wish to use **Color Chooser**, you may opt to manually enter the **Start Color** values in the **RGB** boxes. (**Figure 3, page 32.**)

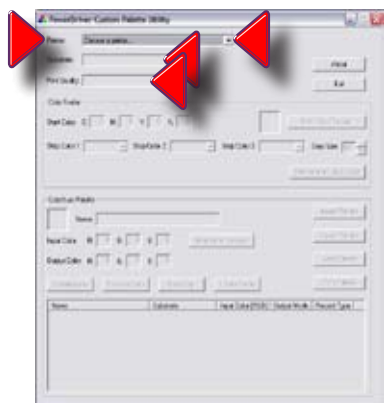

Figure 1

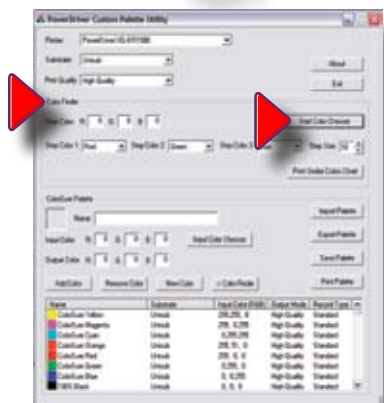

Figure 2

- To use **Color Chooser**, simply click on the **'Start Color Chooser'** button in the **"Color Finder" Section**, at the top right of the **"PowerDriver Custom Palette Utility" Window.** You can then choose a color from the basic color selection, or you can click on the **Color** button at the right of the window. This will display a color matrix. To define a custom color, click anywhere in the matrix. Use the slider at the right of the matrix to adjust luminosity. Clicking **'OK'** will automatically fill the **RGB** boxes with the corresponding values. (**Figure 3**)
- For advanced users, **RGB** values can be determined by printing out a **Custom Palette**, which is outlined in the next section.

Color Chooser Dialog Window

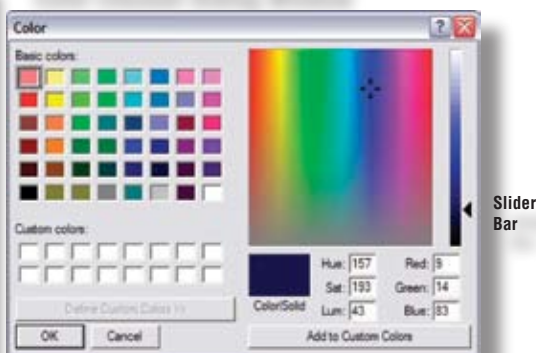
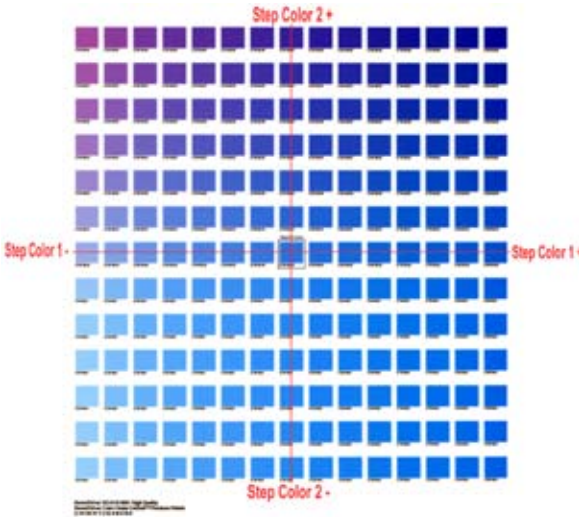

Figure 3

Printing out a Custom Palette

You may alter the chosen color's **RGB** value by selecting two or three Step Colors. Using multiple step colors will present you with a greater range and variety of colors to choose from.

- For instance, if you choose to modify your Start Color with two steps, then Step Color 1 will change its values on the X (horizontal) axis and Step Color 2 will change its values on the Y (vertical) axis.



- If you modify your Start Color with three steps, Step Color 1 will remain the same. However Step Color 2 and Step Color 3 will form an imaginary 'X' and their values will change on opposing diagonal Y axes.

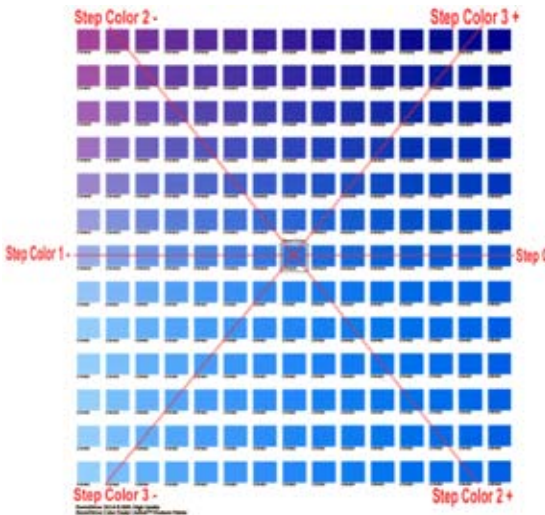

- Next, determine what Step Size you want to apply to the Color Finder palette. This is simply a question of how much you want your Start Color to fluctuate. If your Start Color is close to the color you are looking for, use a low **Step Size**. (i.e. 5-10) However, if your **Start Color** is not close to what you are looking for, use a higher Step Size. You can enter any Step Size value between 1 and 40.
- As an example, let's say your **Start Color** is **R:20, G:80, B:70** and you select **Blue** and **Red** to be your **Step Colors**. You also enter a **Step Size** of **10**. When the '**Print Colors**' button is clicked, your **Start Color** will be in the middle of the Color Finder palette and from there each color will vary the **Blue** and **Red** values by **10**.
- When you are finished selecting the **Start Color**, **Step Colors**, and the **Step Size**, click on the **Print Colors** button. This will print your **Custom Color Finder** palette directly to your printer.
- After printing the **Color Finder** palette, transfer it to your selected substrate and then try to match your desired color to one that is on the palette. If you find a suitable match, you are finished using the **Color Finder** tool. Move on to **Section V, The Custom Palette**.
- If you couldn't find an accurate match on the first printed **Color Finder Palette**, don't worry. Follow the steps below, and you can find a more suitable custom color.
 1. First, try to locate a new **Start Color** from the palette that is closer than the original color.
 2. Next, after finding a more suitable **Start Color**, write down that color's **RGB** value. Here is how to obtain this value. There are numbers under each color that are dependant upon which **Step Colors** you chose. For example, it might say **R:32 G:80**. Take note of these values. Then, at the bottom left of the **Color Finder** palette you will see a full set of **RGB** values. The new **Start Color's RGB** value would be **R:32 G:80** and whatever the **RGB** values are from the full set.
 3. Lastly, plug the **RGB** values for the new **Start Color** into the boxes in **Color Finder**, choose your **Step Size**, and click on **Print Colors** once again. Continue with steps **1-3** until you find your desired color.

V. The Custom Palette

Let us assume that you have found the exact color you need using the **Color Finder** tool. What you will want to do next is apply these custom color values to either an existing palette, or to create a new custom palette altogether. This allows you access to this color again should the same job arise.

How to use Custom Palette:

- First, you need to assign the **RGB** values of the matched color from the **Color Finder** palette to the **Output Color RGB** fields in the **Custom Palette** section.
 - Give your new custom color a descriptive Name in its designated field (e.g. **IBM Blue**).
 - Next, assign an **RGB Input Color Value**. There are two methods to establish this value.
 1. If you have the original file, sample the color that was matched in your graphic design application with the eye dropper tool. This will give you the **RGB** value of that color. Input this value into the **RGB Input Color** fields of the **Custom Palette** section.
 2. If you do not have the original file or the artwork has not yet been designed, simply click on the **'Input Color Chooser'** button, and then click on **"Define Custom Colors"**. From the color matrix, find a color that closely resembles the color that you are adding to the custom palette. At the bottom-right of the color matrix window are the **RGB** values. Simply click 'OK' and the **RGB** Input Color values will be automatically entered. Please take note of these **RGB** values for later use in your design applications.
 - Click the Add Color button. A window will pop up asking you whether you want to add the color to the palette for all substrates or just the current substrate. Click **'YES'** here unless you have the same custom color saved on palettes for other substrates. Another window will then ask you if you want to save the custom color for all resolutions or just the current one. Click **'YES'** here unless you have the same custom color saved on palettes for other resolutions.
 - Lastly, click the **Save Palette** button. When finished, simply **Exit** out of the window.
- * The **'Import Palette'** and **'Export Palette'** buttons are convenient to have in the event you need to transfer palettes to and from different computers.

VI. Adding Swatches to your Application Palette:

It is possible to add your custom color(s) swatch to an application palette as well. You will need to take note of the **Input Color RGB** value that you assigned in the previous step in order to create the new swatch. Refer to your specific design application software's manual for instructions on this.

Selecting Paper

For information on selecting the appropriate paper to use with your SubliJet R™ inks, please check our website at <http://www.sawgrassink.com> or call your authorized SubliJet reseller. While the use of copy paper or other inkjet paper will not harm your printer, the transferred results may be light, splotchy, or uneven. Some papers may even stick to the surface or leave a visible residue.

Heat Transfer Instructions

Because you can print on a variety of surfaces, you need to take all variables of the surface into account when selecting time, temperature, and pressure. Some of the variables are:

- Thickness of surface.
- Heat absorption; how fast the surface absorbs heat.
- Coatings used on materials to create a receptive surface for sublimation inks. (Ceramics, Metals, Plastics, etc.)
- Accuracy of heat press unit. (Time, Temperature, and Pressure)

The information listed below are only guidelines. Due to the differences in heat presses and the various materials you will be printing on, it is not possible to give absolute figures. You should check with your supplier for specific heat transfer instructions or experiment to find your own preferred settings.

SURFACE	Transfer Time SubliJet	Transfer Time SubliJet R	TEMP	P. S. I.	REMARKS
CERAMIC	150-210 Seconds	150-210 seconds	350-400°F	40 psi	Time varies with press, use green tile mat for ceramic tile
FR PLASTIC	33 seconds	75-80 seconds	400°F	40 psi	Remove Plastic
METAL (Other) White, Silver, Gold	40 seconds	60 seconds	375°F - 400°F	40 psi	Time varies with metal manufacturer (Contact your reseller for correct time and temperature) Place absorbent sheet on bottom plate of heat press. Then place transfer paper face up on top of the absorbent. Next place the substrate face down on top of the transfer paper. Remove paper from substrate immediately after transferring for best results.
METAL (Universal Woods)	40 seconds	60 seconds	400°F	40 psi	Use absorbent, remove plastic
MOUSE PADS	25 seconds	45 seconds	400°F	40 psi	
POLYESTER FABRIC & PERFORMANCE APPAREL	25 seconds	45 seconds	400°F	40 psi	
SOFT L'INK™	25 seconds	35 seconds	400°F	40 psi	Press for 5 secs to eliminate moisture, use Teflon sheet between sides of shirt to prevent "blow through"
UNISUB™ PRODUCTS	75 seconds	75-85 seconds	400°F	40 psi	Remove Plastic



Tips for Successful Sublimation

POLYESTER FABRIC

Maintain appropriate heat press times.

- Shortened pressing times will result in good surface color but the sublimation dyes will not completely penetrate the polyester fibers. This leaves the dyes more susceptible to wash out.
- Longer pressing times will cause the dye molecules to penetrate deeper into the fiber, creating a washed out look. For guidelines on transfer times, see the **Section** entitled **Heat Transfer Instructions, page 35.**

Maintain appropriate heat press temperatures & pressure

- The correct temperature setting is vital for achieving desired results. Higher temperatures can damage the polyester fibers to the point that they cannot properly “**hold**” the dyes. For guidelines on transfer temperatures, see the **Section** entitled **Heat Transfer Instructions, page 35.**
- Too much pressure on the heat press may cause the dyes to penetrate too deeply into the fabric causing a washed out look. For guidelines on transfer pressure see the **Section** entitled **Heat Transfer Instructions.**

METAL

To obtain the best results when printing onto metal, place the transfer between the metal and an absorbent cloth or fresh, non-textured paper towel. This will absorb any dyes that pass back through the paper and any moisture released during the transfer process. If you have problems with inconsistently filled areas, this may alleviate the problem.

CERAMIC TILES & MUGS

When transferring onto ceramic tiles and mugs, immediately peel the paper off of the ceramic after removing it from the heat press. Once the paper has been removed, cool the ceramic by submerging it in cool water, or run water over it from the faucet. If paper residue remains on the surface of the ceramic, clean with citrus cleaner. If you experience a significant paper-sticking problem, call your SubliJet reseller for assistance.

Polyester T-Shirts

- The presence of moisture in your fabric can lead to bleeding of the image. Remove moisture by pre-pressing your shirt for **10** seconds. Use **Teflon®** sheets between the front and back of the shirt to prevent the inks from penetrating to the other side of the shirt. If dye residue from your heat press is being deposited on your shirts at any time, heat press a paper towel or similar absorbent material to remove it.
- Using a lint brush before pressing can greatly reduce lint or debris on the shirt.

MOISTURE & HUMIDITY PROBLEMS

The addition of moisture to the sublimation process can cause unwanted results. Under normal circumstances, the small amount of moisture that can accumulate in your paper is absorbed directly into the transfer substrate; however hard substrates like metal and ceramic are unable to absorb excess moisture. Some of problems that are attributed to moisture include: color shifting (colors lose accuracy), bleeding of the image, and uneven transfer of solid filled areas.

To avoid these problems

- Keep your paper in a dry place.
- If you suspect moisture, set the paper on your press for a few seconds. Do not press it. Just expose it to the warmth. The heat radiating from the press should help evaporate most of the moisture.
- To eliminate moisture in fabric, press the fabric for 10 seconds before doing the heat transfer.
- Use an absorbent cloth or fresh, non-textured paper towel behind the transfer sheet to absorb the moisture.

Supplies & Equipment

Contact your reseller to purchase sublimation supplies and equipment. For more information see the dealer locator option on our website at: www.sawgrassink.com.

Operating Conditions

Certain environmental conditions should be taken into account for the operation of **SubliJet R** inks, including temperature and relative humidity.

- Supported Operating Conditions are 65° – 80° F with 40 – 60% relative humidity
- Optimum Operating Conditions are 68° – 75° F with 40 – 60% relative humidity

Storage

- Care should be taken to prevent storing SubliJet below freezing temperatures (32°F, 0°C). Do not expose SubliJet to extreme heat (temperatures in excess of 104°F, 40°C). If SubliJet has been in storage, you should allow it to reach room temperature before using it.
- Do not expose SubliJet cartridges directly to light, especially sunlight, for extended periods.
- For best results, install your SubliJet cartridges by the date on the cartridge. Please refer to the individual ink bag/cartridge for the specific ink expiration date.

Troubleshooting

The troubleshooting tips found in this section relate mainly to problems that can be seen in transferred **SubliJet** images. If you are having problems related to the performance of your printer, please refer to the **Problem Solving** section found in the **Ricoh GX7000 Printer User's Guide**.

My Image Has Gaps or Bands Present.

- Ensure that all of the printer's nozzles are firing properly. Perform a **Nozzle Check** from the **Utility tab** of your printer driver. For further instructions, see the **Ricoh GX7000 Printer User's Guide**.
- If one or more of the nozzles fail to print, perform a **Print Head Cleaning**. For further instructions, see the **Ricoh GX7000 Printer User's Guide**.
- Check to make sure all **OEM driver firmware** has been updated per the OEM driver installation instructions in the PowerDriver R section.
- If all nozzles are showing, check the **Adjust Print Head Position & Adjust Paper Feed** options within the OEM driver to ensure the optimum alignment for correct printing. For instructions on how to use these features, please reference the Ricoh User's Guide found on the driver CD provided with your printer.

The printer keeps showing a “Maintenance in Process.” message on the LED screen.

- To help keep optimum printing conditions and reduce missing or clogged nozzles, this printer has a self cleaning mode. When this message appears, the printer is doing a cleaning and will resume printing when it is complete.

The colors in my transferred image are incorrect

- The image may need color adjustment. Use **PowerDriver** color matching software. For more information on how to use this software, please see the section entitled **PowerDriver R Ricoh GX7000 User's Guide**.
- Ensure you used the right printer driver and driver settings. Please see the section entitled **PowerDriver R Ricoh GX7000 User's Guide**.
- Ensure you pressed the item with the proper time, temperature, and pressure. For guidelines see the section entitled **Heat Transfer Instructions**.
- Verify all colors print correctly. Run the **Nozzle Check** utility and clean the print heads as required.

My printout is really light on paper

- **SubliJet R** ink naturally looks muted before the heat transferring of the image. After transferring is complete, **SubliJet's** unique inks will produce a brilliant and durable final product.

My printout gets cut off on the bottom or side

- Verify the printer driver is setup for the correct paper size. Your printer driver setting needs to match the paper size that is loaded in your printer.
- Ensure the right paper guide is in the proper position. When setting up the printer, slide the right paper guide to the left until it clicks into position.

Colors are light and splotchy, (Cont.)

- Verify your printer driver settings are correct. Please see the section entitled **PowerDriver R Ricoh GX7000 User's Guide** for additional information.
- Ensure you do not have a moisture problem. For more information, see the **Section** entitled **Moisture and Humidity** on the **Tips for Successful Sublimation** page.
- Ensure your substrate is designed to accept a sublimation transfer. Garments made from natural fibers such as **Cotton** are not compatible with the sublimation process.

My Image Looks Blurred.

- Ensure you pressed the item with the proper time, temperature, and pressure. For guidelines, see the **Section** entitled **Heat Transfer Instructions**.
- Ensure you used a recommended paper. For more information, see the section entitled **Selecting Paper**.
- Ensure you printed on the correct side of the paper. The print side is the bright white side of the paper.
- Ensure you do not have a moisture problem. Try drying the paper on the press or putting a paper towel behind the transfer when you heat press it. Read the **Section** entitled **Moisture and Humidity** on the **Tips for Successful Sublimation**.
- Verify that the printer's print heads are properly aligned. For further instructions, see the **Ricoh GX7000 Printer User's Guide**.

My image looks good but it washes out

- Ensure you pressed the garment with the proper time, temperature, and pressure. If so, try pressing longer to ensure that the dyes are penetrating the fibers sufficiently. For guidelines, see the section entitled **Heat Transfer Instructions**.
- Ensure you used a recommended paper. See the section entitled **Selecting Paper**.
- Ensure your substrate is designed to accept sublimation transfers. Garments made from natural fibers, such as cotton, are not compatible with the sublimation process.

Colors are light and splotchy

- Ensure you printed on the correct side of the paper. The print side is the bright white side of the paper.
- Ensure you used a recommended paper. For more information, see the section entitled **Selecting Paper**.
- Ensure you pressed the item with the proper time, temperature, and pressure. For guidelines, see the section entitled **Heat Transfer Instructions**.

Technical Support

If you are having difficulties achieving good results from your **SubliJet R™** inks, you have several support options:

1. **Telephone:** You may contact your authorized **SubliJet** reseller during their normal hours of operation for assistance. A full listing of authorized **SubliJet Resellers** is available on our **Website** at www.sawgrassink.com.

In addition, you may also contact **Sawgrass Technical Support** at **(888) 253-1679** during hours **8:30 AM** until **5:30 PM Eastern Standard Time**.

2. **Internet:** Visit the **Technical Support Area** of the **Sawgrass Technologies, Inc. Website** at www.sawgrassink.com. The troubleshooting utility found here will provide you with solutions to some of the most common problems. You may submit a detailed description of your problem if you need further assistance.
3. **E-mail:** You may **e-mail Sawgrass Technical Support** with a detailed description of your problem at support@sawgrassink.com.
4. **Fax:** You may fax a detailed description of your problem to **Sawgrass Technical Support** at **(843) 849-3847**.

Project Sublimation

Whether you are a current business owner adding sublimation to your line-up, a novice/intermediate sublimation user who would like to learn more, or an entrepreneur exploring the dye-sub industry, **Project Sublimation** is the industry's choice for practical, hands-on instruction. From equipment and product overview to marketing and pricing your products; from the science of sublimation to color management, our two-day, interactive workshop series will give you the background and know-how needed to run a full-service sublimation business.

At **Project Sublimation** workshop events, you will also have the opportunity to network with fellow sublimation users across the **US** and **Canada**. The new, enhanced **Project Sublimation Website** gives attendees access to the full business assets and forums, an invaluable resource for growing your sublimation business.

Isn't it time you took your business to the next level?

Project Sublimation travels to cities throughout the **United States** and **Canada**. Join us in a city near you for this dynamic, full-service workshop. Spend two days with one of our experts and get a leg up on your competition.

Please visit us on the web at www.ProjectSublimation.com or phone us toll free at **1.888.780.7349**.

