

SubliJet IQ™

Getting Started Guide

For EPSON Stylus® PRO 4800



Revision 10/2005

SubliJet IQ™
Getting Started Guide
for the
EPSON Stylus® PRO 4800

© Copyright 2005, Sawgrass Technologies, Inc., Revision October 2005. All rights reserved. Printed in the United States of America.

SubliJet® is a registered trademark of Sawgrass Technologies, Inc. SubliJet IQ™ is a registered trademark of Sawgrass Technologies, Inc. Epson® and Stylus® are registered trademarks of Seiko Epson Corporation.

Other trademarks and registered trademarks are the property of their respective owners.

No part of this manual may be reproduced or transmitted in any form by any means without the prior written consent of Sawgrass Technologies, Inc. Information in this manual is subject to change without notice and does not represent a commitment on the part of Sawgrass Technologies, Inc.

IMPORTANT – READ CAREFULLY:

This Process License Agreement (“PLA”) is a legal agreement between you and Sawgrass Technologies, Inc. (“Sawgrass”). By installing the SubliJet IQ ink in your printer, or otherwise using the Sawgrass SubliJet IQ ink, you agree to be bound by the terms of this PLA. If you do not agree to the terms of this PLA, Sawgrass is unwilling to license the process of using the SubliJet IQ ink to you. In such event, you may not use the SubliJet IQ ink, and you should promptly contact your supplier for instructions on return of the unopened package.

The process of using the SubliJet IQ ink is protected by U.S. and foreign patents. Sawgrass will provide a complete list of the relevant patents upon request. The use of the SubliJet IQ ink to practice the patented process is permitted by this license.

GRANT OF LICENSE This PLA grants you the following rights: You may install and use the SubliJet IQ ink packaged herewith in your EPSON printer to practice the printing process described in U.S. Patent No. 5,488,907. The use of any ink, dye, or pigment to practice the Sawgrass Process, other than a SubliJet IQ ink purchased from Sawgrass or its authorized distributor accompanied by a PLA, is not a licensed use of the Sawgrass Process. No rights to use the Sawgrass Process, except those specified herein, are granted, and no rights to use any other process, product, software, or hardware developed or sold by Sawgrass are granted or implied hereby.

LIMITATIONS ON REVERSE ENGINEERING You agree that you will not attempt to reverse engineer, reproduce, or de formulate the SubliJet IQ ink.

PATENTS AND COPYRIGHTS Sawgrass owns multiple U.S. and foreign patents which apply to the Sawgrass Process and/or the SubliJet IQ ink or its use. All patents in and to the SubliJet® ink and the method of using the SubliJet IQ ink are owned by Sawgrass Technologies, Inc. You may not copy the printed materials accompanying the SubliJet IQ ink. All rights not specifically granted under this PLA are reserved by Sawgrass Technologies, Inc.

Made In U.S.A.

CAUTION:

- For best printing results, use the ink within six months of purchase. Please refer to the individual ink bag/cartridge for the specific ink expiration date.
- Keep out of reach of children.
- Do not expose ink to temperatures above 100° F or below 40° F.
- Keep ink out of direct sunshine.

Sawgrass Technologies, Inc. agrees to replace any defective ink within a reasonable time, which shall be Sawgrass' sole responsibility for errors or defects in these goods.

THERE ARE NO OTHER WARRANTIES, EXPRESSED OR IMPLIED, INCLUDING, BUT NOT LIMITED TO, ANY IMPLIED WARRANTY OF MERCHANTABILITY OR ANY IMPLIED WARRANTY OF FITNESS FOR A PARTICULAR PURPOSE. SAWGRASS SHALL NOT BE LIABLE FOR LOSS OF PROFIT OR OTHER ECONOMIC LOSS, OR FOR INDIRECT, SPECIAL, CONSEQUENTIAL OR OTHER SIMILAR DAMAGES.

END-USER LICENSE AGREEMENT FOR SAWGRASS SOFTWARE- PowerDriver IQ® , PowerDriver XG® , and PowerDriver XG⁸®

IMPORTANT-READ CAREFULLY: This Sawgrass Technologies Inc. End-User License Agreement ("EULA") is a legal agreement between you (either an individual or a single entity) and Sawgrass Technologies, Inc for the Sawgrass software product identified above, which includes computer software and may include associated media, printed materials, and "online" or electronic documentation ("SOFTWARE PRODUCT"). By installing, copying, or otherwise using the SOFTWARE PRODUCT, you agree to be bound by the terms of this EULA. If you do not agree to the terms of this EULA, do not install or use the SOFTWARE PRODUCT.

Software PRODUCT LICENSE

Copyright laws and international copyright treaties, as well as other intellectual property laws and treaties protect the SOFTWARE PRODUCT. The SOFTWARE PRODUCT is licensed, not sold. The title to, and ownership of, this SOFTWARE PRODUCT remains with Sawgrass Technologies, Inc. (Sawgrass).

GRANT OF LICENSE. This EULA grants you the following rights:

- This license is provided to you for your use according to the terms hereof. You may install and use the SOFTWARE PRODUCT packaged herewith to practice the printing process described in U.S. Patent No. 5,488,907 (the "Sawgrass Process"). The use of any ink, dye or pigment to practice the Sawgrass Process, other than a SubliJet ink which is purchased from Sawgrass or its authorized distributor, is not a licensed use of the SOFTWARE PRODUCT. You agree not to use the SOFTWARE PRODUCT for any other purpose or in any process except as expressly permitted hereby.
- Not for Resale. You may not sell, or otherwise transfer for value, the SOFTWARE PRODUCT.
- No Reverse Engineering, Decompilation, Copying or Disassembly. You may not reverse engineer, decompile, copy or disassemble the SOFTWARE PRODUCT.
- No Rental. You may not rent, lease, or lend the SOFTWARE PRODUCT.
- Support Services. Sawgrass Technologies, Inc. may provide you with support services related to the SOFTWARE PRODUCT ("Support Services"). Use of Support Services is governed by the Sawgrass policies and programs described in the user manual, in "online" documentation, and/or in other Sawgrass-provided materials. Any supplemental software code provided to you as part of the Support Services shall be considered part of the SOFTWARE PRODUCT and subject to the terms and conditions of this EULA. With respect to technical information you provide to Sawgrass as part of the Support Services, Sawgrass may use such information for its business purposes, including for product support and development. Sawgrass will not utilize such technical information in a form that personally identifies you.
- No Assignment or Sublicense. You may not assign or sublicense the rights granted hereby.
- Termination. Without prejudice to any other rights, Sawgrass may terminate this EULA if you fail to comply with the terms and conditions of this EULA. In the event of termination, you must destroy all copies of the SOFTWARE PRODUCT and all of its component parts.

COPYRIGHT. All title and copyrights in and to the SOFTWARE PRODUCT (including but not limited to any images, photographs, animations, video, audio, music, text, and "applets" incorporated into the SOFTWARE PRODUCT), the accompanying printed materials, and any copies of the SOFTWARE PRODUCT are owned by Sawgrass Technologies Inc. or its suppliers. Copyright laws and international treaty provisions protect the SOFTWARE PRODUCT. Therefore, you must treat the SOFTWARE PRODUCT like any other copyrighted material, except that you may install the

SOFTWARE PRODUCT on a computer for the uses permitted hereby. You may not copy the printed materials accompanying the SOFTWARE PRODUCT. You may not loan, rent, lease, or otherwise transfer the other medium to another user, except as part of the permanent transfer (as provided above) of the SOFTWARE PRODUCT.

U.S. GOVERNMENT RESTRICTED RIGHTS. The SOFTWARE PRODUCT and documentation are provided with RESTRICTED RIGHTS. Use, duplication, or disclosure by the Government is subject to restrictions as set forth in subparagraph (c)(1)(ii) of the Rights in Technical Data and Computer Software clause at DFARS 252.227-7013 or subparagraphs (c)(1) and (2) of the Commercial Computer Software-Restricted Rights at 48 CFR 52.227-19, as applicable.

MISCELLANEOUS

- a. If you acquired this product in the United States, this EULA is governed by the laws of the State of South Carolina. In the event of any dispute arising under this license or from the use of the SOFTWARE PRODUCT, each party irrevocably agrees to the jurisdiction of the United States District Court for the District of South Carolina, Charleston Division.
- b. If you acquired this product in Canada, this EULA is governed by the laws of the Province of Ontario, Canada. In the event of any dispute arising under this license or from the use of the SOFTWARE PRODUCT, each party irrevocably agrees to the jurisdiction of the courts of the Province of Ontario and further agrees to commence any litigation which may arise hereunder in the courts located in the Judicial District of York, Province of Ontario.
- c. If this product was acquired outside the United States, then local law may apply.

LIMITED WARRANTY. Sawgrass warrants that (a) the SOFTWARE PRODUCT will perform substantially in accordance with the accompanying written materials for a period of thirty (30) days from the date of receipt, and (b) any Support Services provided by Sawgrass shall be substantially as described in applicable written materials provided to you by Sawgrass, and Sawgrass support engineers will make commercially reasonable efforts to solve any problem issues. Some states and jurisdictions do not allow limitations on duration of an implied warranty, so the above limitation may not apply to you. To the extent allowed by applicable law, implied warranties on the SOFTWARE PRODUCT, if any, are limited to thirty (30) days.

CUSTOMER REMEDIES. Sawgrass' and its suppliers' entire liability and your exclusive remedy shall be, at Sawgrass' option, either (a) return of the price paid, if any, or (b) repair or replacement of the SOFTWARE PRODUCT that does not meet Sawgrass' Limited Warranty and which is returned to Sawgrass with a copy of your receipt. This Limited Warranty is void if failure of the SOFTWARE PRODUCT has resulted from accident, abuse, or misapplication. Any replacement SOFTWARE PRODUCT will be warranted for the remainder of the original warranty period or thirty (30) days, whichever is longer. Outside the United States, neither these remedies nor any product support services offered by Sawgrass are available without proof of purchase from an authorized international source.

NO OTHER WARRANTIES. To the maximum extent permitted by applicable law, Sawgrass and its suppliers disclaim all other warranties and conditions, either express or implied, including, but not limited to, implied warranties of merchantability, fitness for a particular purpose, title, and non-infringement, with regard to the SOFTWARE PRODUCT, and the provision of or failure to provide Support Services. This limited warranty gives you specific legal rights. You may have others, which vary from state/jurisdiction to state/jurisdiction.

LIMITATION OF LIABILITY. To the maximum extent permitted by applicable law, in no event shall Sawgrass or its suppliers be liable for any special, incidental, indirect, or consequential damages whatsoever (including, without limitation, damages for loss of business profits, business interruption, loss of business information, or any other pecuniary loss) arising out of the use of or inability to use the SOFTWARE PRODUCT or the provision of or failure to provide Support Services, even if Sawgrass has been advised of the possibility of such damages. In any case, Sawgrass' entire liability under any provision of this EULA shall be limited to U.S. \$5.00. Because some states and jurisdictions do not allow the exclusion or limitation of liability, the above limitation may not apply to you.

SubliJet IQ®, PowerDriver IQ®, PowerDriver XG®, and PowerDriver XG® are registered trademarks of Sawgrass Technologies, Inc. ColorSure™ is a trademark of Sawgrass Technologies, Inc.

General Notice: Other product names used herein are for identification purposes only and may be trademarks of their respective owners. Sawgrass Technologies, Inc. disclaims any and all rights in those marks.

Table of Contents

Table of Contents	5
Introduction	6
About this Document	7
Installing SubliJet IQ™ Cartridges	8
Selecting Paper	11
Heat Transfer Instructions	12
PowerDriver Introduction	14
System Requirements	14
Setup Instructions – Windows 2000 and XP	15
Using PowerDriver XG ⁸ in Windows 2000 / XP	20
Appendix A: Network Printing in Windows 2000, XP	26
Host Machine (Server)	26
Appendix B: Defeating Application Color Management	27
Appendix C: Using ColorSure™ and Custom Palette	32
Appendix D: Custom Paper Sizes	39
Tips for Successful Sublimation	40
Supplies & Equipment	42
Operating Conditions	42
Storage	42
Troubleshooting	43
Technical Support	46
Project Sublimation	46

Introduction

Congratulations on your purchase of SubliJet IQ™ digital transfer inks. The SubliJet IQ™ sublimation ink cartridges are the latest advancement for the EPSON Stylus PRO 4800 from Sawgrass Technologies, Inc., a leader in the development of digitally driven color transfer technologies and related products.

Discover the new, smart choice for extraordinary profitability and value - SubliJet IQ with the Epson Stylus Pro 4800. Imagine printing 20 t-shirt transfers in approximately 17 minutes! Now imagine how many mugs you could print in the same time frame! The SubliJet IQ Epson 4800 System is offered with our Red/Blue XG⁸ system option. This revolutionary, comprehensive approach takes sublimation to the professional level, allowing users to create perfect transfers with minimal effort. With true eight-color printing, the XG8 System increases color gamut, creates noticeably smoother gradient transitions, captures finer detail and adds color depth. The Red & Blue inks achieve true blues and richer reds for better spot colors and the Light Cyan and Light Magenta create the ultimate photo advantage with more realistic flesh tones and improved image quality.

In addition, your system is bundled with PowerDriver XG⁸, a user-friendly color management software package that allows the user to create flawless transfers in less time. The "Fast Copies" option reduces print time by automatically spooling the file to the printer only once regardless of the number of copies. Design time is also condensed by utilizing the ColorSure Palette. The color palette contains 160 more spot colors and the custom palette utility gives users the ability to add, edit, import or export colors, thus streamlining the color matching process. Instructions for installation and use of this system can be found in this User's Guide under the PowerDriver instruction section.

This document contains information for using SubliJet IQ™ inks and the helpful tips are provided for getting the best results from your transfers. The information provided pertains only to the use of SubliJet IQ™ in your EPSON Stylus PRO 4800 printer. If you have questions about the operation of your EPSON printer, refer to the *EPSON Stylus PRO 4800 Printer User's Guide*.

Technical support is available from your Authorized SubliJet reseller or directly from Sawgrass Technologies, Inc. See the section entitled *Technical Support* for additional information.

We at Sawgrass strive to provide you with the tools to make the sublimation process easy to learn and simple to master. We hope you will find that the tools we have developed will make your years in the sublimation business fun and profitable. Please feel free to contact us with your feedback about our products. For additional information on our other products, visit our web site at www.sublimation.com.

Thank you and enjoy your SubliJet IQ™ printing system.

About this Document

This document contains descriptions and procedures for using SubliJet IQ™ ink, along with additional information for getting the best results from your transfers.

The documentation provided pertains only to the use of SubliJet IQ™ ink in your EPSON Stylus PRO 4800 ink jet printer. To assist you in the overall setup process, references are made back to the *EPSON Stylus PRO 4800 Quick Reference Guide* for instructions.

To help point out important information, specific instructions, and helpful tips look for the following symbols:



Indicates **Must-Do** items, including warnings and important guidelines. These must be followed to prevent damage to your printer.



Indicates useful tips for printing and sublimation.

Installing SubliJet IQ™ Cartridges



Do not install the Epson Inks provided with the printer. Please call Sawgrass Technical Support if you need assistance installing the SubliJet IQ inks.

If you are replacing existing cartridges because they are empty or low, please see the following instructions. If not, go directly to step #1

When a cartridge is empty or low, INK LOW or INK OUT will display on the LCD panel. The ink indicator - 8 bars which represent the 8 cartridges on the LCD Panel - will flash indicating which cartridge is low or empty. Ensure you have the correct color cartridge for replacement.

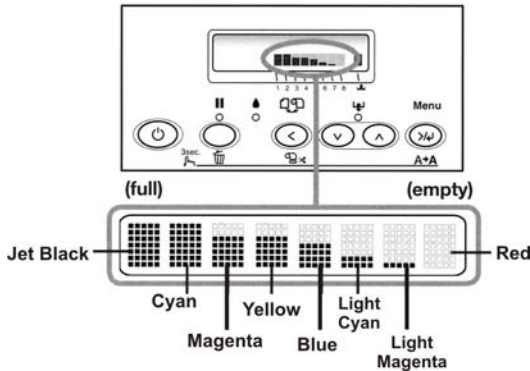

1. Ensure the printer power is on. Press the ink compartment cover to release the latch and open the cover.

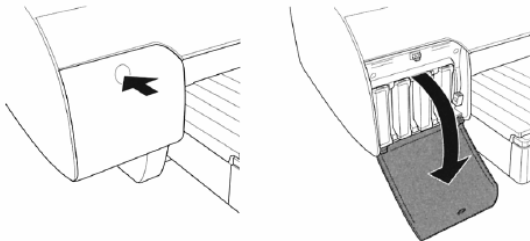

2. Raise the ink lever to the unlocked position. The ink lever is located to the right of each ink compartment.

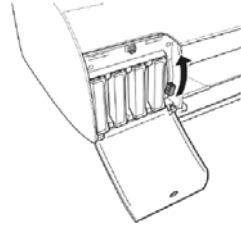

3. Remove the empty ink cartridge from the printer.

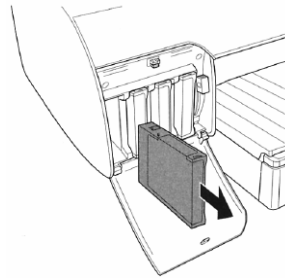

4. Remove the replacement ink cartridge from its packaging and insert it into the slot with the label facing left. Do not force the cartridge into the slot.

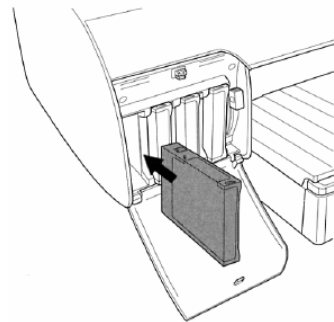

If the cartridge does not insert smoothly into the slot, double check to make sure you have the correct cartridge installed in the correct slot. If the ink light remains on after installing the cartridge, remove the cartridge and reinsert to ensure it was fully placed in the slot.

5. Lower the ink lever in to the locked position.

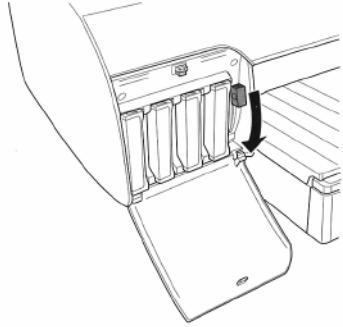

6. Close the ink compartment cover if you have standard size ink cartridges installed. If you have extended cartridges installed in the printer, you will need to leave the cover open.

7. Once the cartridge is installed the printer will return to its READY state.

8. This completes your install.

Selecting Paper

For information on selecting the appropriate paper to use with your SubliJet IQ™ inks, please check our website at <http://www.sublimation.com/support/> or call your authorized SubliJet reseller. While the use of copy paper or other inkjet paper will not harm your printer, the transferred results may be light, splotchy, or uneven. Some papers may even stick to the surface or leave a visible residue.

Heat Transfer Instructions

Because you can print on a variety of surfaces, you need to take all variables of the surface into account when selecting time, temperature, and pressure. Some of the variables are:

- thickness of surface,
- how fast the surface absorbs heat,
- coatings used on the material to create a receptive surface for sublimation inks (ceramics, metals, etc.),
- accuracy of heat press (time, temperature, and pressure).

The information listed below are only guidelines. Due to the differences in heat presses and the various materials you will be printing on, it is not possible to give absolute figures. You should check with your supplier for specific heat transfer instructions or experiment to find your own preferred settings.

SURFACE	TRANSFER TIME SUBLIJET IQ	TEMP	PRESSURE	REMARKS
CERAMIC	150-210 seconds	350-400°F	40 psi	Time varies with press, use green tile mat for ceramic tile
FR PLASTIC	75-80 seconds	400°F	40 psi	Remove Plastic
METAL (Other) White, Silver, Gold	60 seconds	375°F - 400°F	40 psi	Time varies with metal manufacturer (<i>Contact your reseller for correct time and temperature</i>) Place absorbent sheet on bottom plate of heat press. Then place transfer paper face up on top of the absorbent. Next place the substrate face down on top of the transfer paper. <i>Remove paper from substrate immediately after transferring for best results.</i>
METAL (Universal Woods)	60 seconds	400°F	40 psi	Use absorbent, remove plastic
MOUSEPADS	45 seconds	400°F	40 psi	
POLYESTER FABRIC & PERFORMANCE APPAREL	45 seconds	400°F	40 psi	
SOFT L'INK™	35 seconds	400°F	40 psi	Press for 5 secs to eliminate moisture, use Teflon sheet between sides of shirt to prevent "blow through"
TEC FILM	210 seconds	350°F	40 psi	
UNISUB™ PRODUCTS	75-85 seconds	400°F	40 psi	Remove Plastic



User Guide

Rev 8.0.0

For distribution with SubliJet IQ®
only
NOT FOR RESALE

PowerDriver Introduction

Obtaining the benefits of PowerDriver color management is now incredibly easy - simply print from your application with PowerDriver XG⁸ rather than the Epson printer driver. PowerDriver prints your image just like the Epson printer driver except for the colors. Watch how it magically makes SubliJet colors picture perfect!

PowerDriver delivers both convenience and the highest quality SubliJet color management technology. The innovation demonstrated by PowerDriver is the result of our dedication to you, our customers. At Sawgrass Technologies, we are focused on delivering the highest quality digital transfer technology available. We fully expect that you will be “wowed” by the results you obtain with SubliJet and PowerDriver.

PowerDriver Version	Ink Setup	Operating System
<u>PowerDriver</u> <u>XG⁸</u>	8 Color with Red / Blue (Cyan, Magenta, Yellow, Jet Black, Light Cyan, Light Magenta, Red, and Blue)	Windows 2000 / XP

System Requirements

Minimum Hardware:

Pentium 4 – 2.0GHz or Athlon XP 2000+ Processor
 512 MB System Memory
 Windows 2000/XP

Recommended Hardware:

Pentium 4 – 3.0GHz or Athlon XP 2500+ Processor
 1 GB System Memory
 Windows 2000/XP

Setup Instructions – Windows 2000 and XP

Product Overview

PowerDriver XG⁸ is a color management software solution that has been written as a Windows printer driver. It is designed to work with Epson ink-jet printers and Sawgrass sublimation ink. The installation program will install Sawgrass color management software, the Sawgrass PowerDriver XG⁸ printer driver software, and ColorSure tools and utilities.

Quick Start

1. Unpack and setup printer as described in the Epson manual.
2. Install the Epson printer driver and verify printer operation.
3. Insert the PowerDriver XG⁸ CD into the CDROM drive on the computer and install PowerDriver.

Step By Step Installation

To get started printing as soon as possible, these are the steps Sawgrass recommends you perform while setting up your sublimation printer driver software.

1. Setup the printer according to the Epson instructions.
2. Install your Sawgrass SubliJet ink cartridges.
3. Install the Epson printer driver according to the Epson user's manual.
4. After the Epson driver is installed, check to see which port the printer is set to:
 - a. In XP you can do this by clicking on Start, Printers and Faxes. For XP with the Classic menu enabled or Windows 2000, click Start, Settings, Printers.
 - b. Right click on the Epson printer you just installed and click on the Properties option.
 - c. Select the Ports tab and *write down the port the printer is assigned to*. You may use this later in the PowerDriver XG⁸ software installation.

5. Insert the PowerDriver CD into your CDROM drive. The installation program should run automatically. (If the program does not automatically run, click Start, Run. Browse to your CDROM drive and click on Setup).
6. The Welcome screen is displayed. Click Next to proceed.

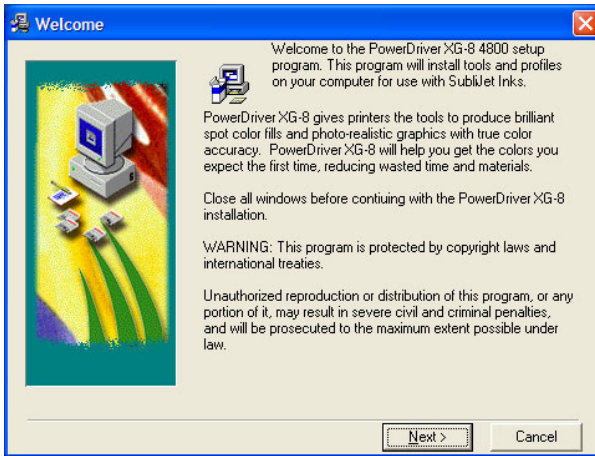

7. The License Agreement is displayed next. Select the appropriate choice for acceptance of the Licensing Agreement to continue.

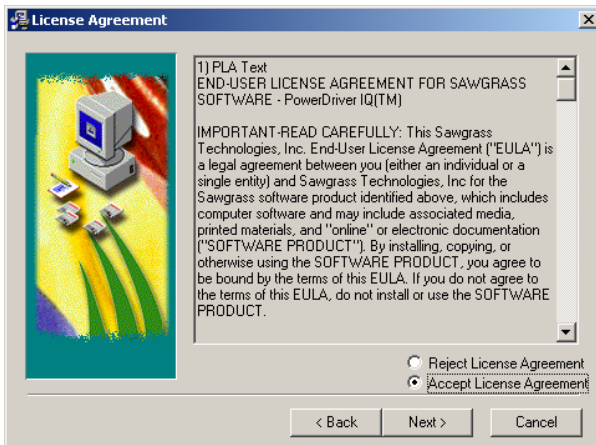

8. If you have not previously registered PowerDriver, you will be prompted to do so. Registering is the only way to take full advantage of the features in PowerDriver XG⁸. If you choose to register later, select Register Later and click Next to proceed with the installation.

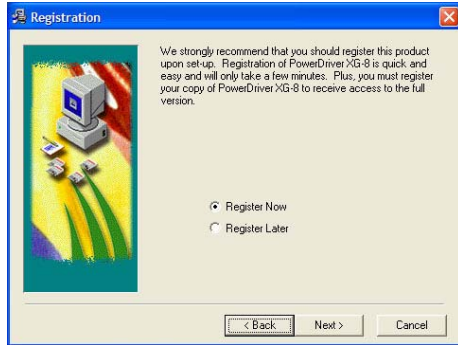

9. If you choose to register now, the registration screen will be displayed. To obtain your registration code you may do so in one of the following ways: Register on-line and receive your registration code via e-mail. Call Sawgrass Technologies, Inc. directly (843) 884-1575 and obtain your code over the phone. Send a fax and receive your registration code by fax.

To register, you will use your Product ID (displayed on the registration screen) to obtain a Registration code. You will need separate registration code for every machine on which PowerDriver XG⁸ is installed. Enter your registration code and click the Apply Code button.

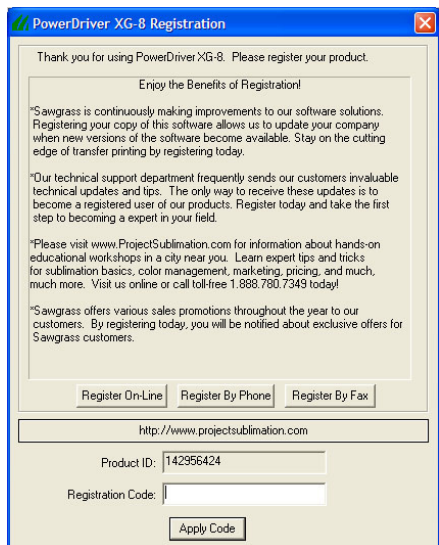

10. Sawgrass Technologies, Inc. provides ColorSure color palettes for use with Corel and Adobe. (Check the ColorSure section of the manual for information on how to use ColorSure to get perfect spot colors). If Setup detects either of these applications on your system, the palette files will be placed in the appropriate folder indicated in the Destination Folder box. Click Next to proceed with the installation.

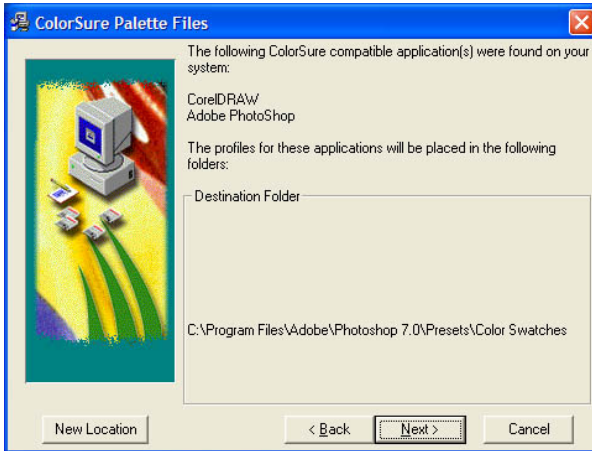

11. The PowerDriver installation program will attempt to use plug-n-play to determine the port that the printer is connected to, click Next to continue. *Note: Cancel any 'Found New Hardware' wizards that may start during this process, do NOT cancel any file copy process however.*



12. If you see the screen below, click Continue Anyway to proceed with the installation.



13. If the installation cannot find the printer port then you will be given the opportunity to choose the port you want to use for the product you are installing. Use the value that was recorded in step 4 above.



14. Once the installation has completed, the Installation Complete screen will display. Click OK to end the installation.

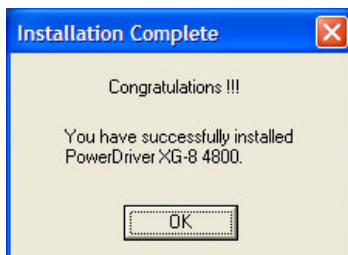

Using PowerDriver XG⁸ in Windows 2000 / XP

PowerDriver XG⁸ is simple to use. Whenever you have SubliJet IQ inks in your printer, you should print using PowerDriver. **Do not** print to your Epson printer with the Epson printer driver; printing with the Epson driver will not give you the benefit of color management.

Quick Start Example (Corel Draw)

- 1) Open/Create an image in Corel Draw.
- 2) Select print from the File menu.
- 3) Select the PowerDriver XG⁸ printer.
- 4) Use the properties button to access and set the Color, Output, Ink and Substrate, Resolution, and Advanced options.
- 5) Click Print.

Setting PowerDriver printer properties

To configure PowerDriver for the correct substrate, you must display its printer properties. There are two ways to display the printer properties:

From the Windows Desktop:

1. Click on Start> Settings> Printers.
2. Right-click on your PowerDriver printer.
3. Select *Properties* from the pop-up menu.
4. Select the *Printing Preferences* button.

From an Application:

1. Select File, Print Setup.
2. Choose the PowerDriver printer from the list of printers.
3. Click the Properties button.

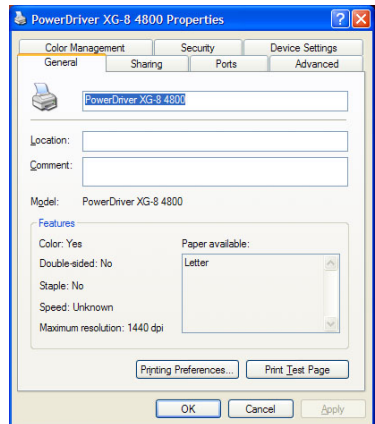

PowerDriver Properties Overview

The following figure shows the printer properties for a registered version of PowerDriver. The Advanced Color Options tab and the Print Palette functions will not be available if the product has not been registered.

There are three main property groups;

Configuration – Set Paper, Transfer Substrate, and Copy Count

Color Settings – Color management control options. (The Color Options group comes in two modes; Easy and Advanced) Both are described below.

Options – Utilities for printer maintenance, online help, product registration, and setting input profiles.

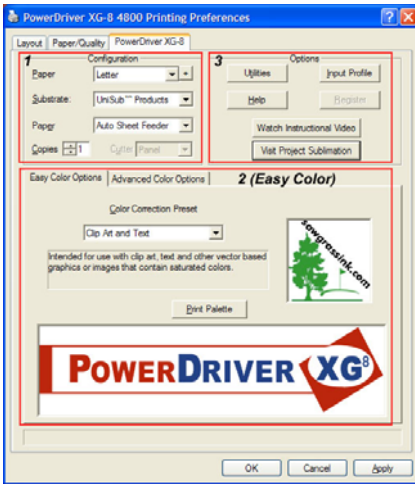

Easy Color Property Page

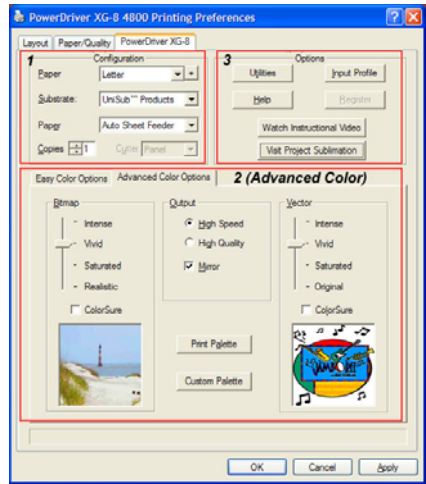

Advanced Color Property Page

Group 1 – Configuration

Paper Size – From the drop down list, select the paper size you wish to use. To add custom paper sizes click the  button to the right of the paper size drop down list. *Note: After adding a custom paper size, the printing preferences dialog must be closed and re-opened before the new paper size will show in the paper size drop down list.*

Substrate – From the drop down list, select the type of material to which you will be transferring your printed image. It is important to choose the correct substrate. PowerDriver XG⁸'s color management is optimized for each different substrate.





Paper Source – From the drop down list, select the paper source you will be using.

Copies – Sets the copy count for the number of prints to be made.

Group 2 - Color Settings (Easy Color Mode)

The Easy Color Option tab provides you with access to a collection of carefully selected color management presets. The right color management choice is essential to making high quality transfers. Easy Color is a fast, simple way of choosing a color management scheme. You choose an Easy Color setting based on the composition of the original image. The chart below lists some guidelines for when to choose different Easy Color settings. Choosing a setting and clicking the apply button automatically sets the bitmap, vector, and output settings found on the advanced tab.

Color Correction Preset – Sets the color correction, the mirror, and the print quality options. The table below describes each Easy Color setting.

Easy Color Icon	Easy Color Description
	<p>Photo – Realistic</p> <p>When to select: If your source image is a photograph, or a photographic scene.</p> <p>Color Management Goal: Realistic color reproduction. The goal is to reproduce the transferred image with color that is as close as possible to the input image.</p>
	<p>Clip Art and Text</p> <p>When to select: If your source image is clip art, text, or a mixture of the two</p> <p>Color Management Goal: The goal is to generate colors that are vivid & contrast well with each other. The overall emphasis is to keep the transferred colors close to the input colors but still add a little extra “pop” to the colors.</p>
	<p>Art Logo</p> <p>When to select: If your source image is clip art, text, or a mixture of the two & you want to increase the intensity of the colors.</p> <p>Color Management Goal: The goal is to generate colors that are vivid & contrast well with each. Unlike the “Clip Art and Text” setting, Art Logo emphasizes vivid output at the expense of color accuracy.</p>
	<p>ColorSure™ Spot Colors</p> <p>When to select: For all image types (bitmaps, scans, clipart, text, etc...) that were designed using the ColorSure palette. (See appendix C for details on using ColorSure to design your artwork).</p> <p>Color Management Goal: Generate consistent output that reproduces colors based on the ColorSure palette.</p>
	<p>ColorSure™ Photos</p> <p>When to select: When you have a mix of bitmap & vector (text, clipart, or shapes) and only the vector elements were designed using the ColorSure palette.</p> <p>Color Management Goal: Generate output that reproduces photographic data using the Photo-Realistic setting and uses ColorSure™ Spot Colors for the vector components of the artwork.</p>

Print Palette Button – Prints the ColorSure palette for the selected substrate. ColorSure is a method for reproducing exact spot colors. The two main

components are; 1) the transferred palette and 2) the CorelDraw, Corel PhotoPaint, and Adobe swatches. For a complete description on how to use ColorSure to get perfect spot colors, see appendix C.

Group 2 - Color Settings (Advanced Mode)

Overview

This tab gives you access to all of the color management controls available in PowerDriver. Color correction allows you to create transfers from all kinds of images, from photorealistic images to spot color logos. For maximum flexibility, PowerDriver lets you color correct bitmap and vector elements differently, even if they are in the same graphics file. For example, if you scan a photograph and import it into CorelDraw, PowerDriver will use the color management settings that have been selected for Bitmap. If you then add text on top of the bitmap image, PowerDriver will use the color management settings that have been selected for Vector. The photograph and the text will be color corrected differently! Why? You can now sublimate images with realistic photographic backgrounds that have vivid spot color text.

Vector and Bitmap Explanation

Bitmaps are a grid of pixels. Bitmaps come from digital cameras, scanners, and photo cds. Bitmaps can also be created in applications like Corel PhotoPaint or Adobe PhotoShop. Bitmaps have file extensions like GIF, JPG, BMP, and TIF. Vector components consist of shapes, curves, lines, and text. They are created in programs such as CorelDraw and Adobe Illustrator. Higher end programs like CorelDraw can combine Vector and Bitmaps into a single image. As a rule of thumb, if the object in your image is made of curves, text, shapes, or fills, it will be color corrected using the PowerDriver Vector settings. All other image types will be color corrected based on the PowerDriver Bitmap setting.

Color Correction Settings

Realistic (Bitmap ONLY) - This setting is most suitable for reproducing skin tones in scanned photographs.

Original (Vector ONLY) - This setting is most suitable for reproducing life-like clipart.

Saturated - The Saturated setting will make the colors in your image more intense. Saturated output tries to remain color accurate with a slight bump in intensity.

Vivid – This setting is most suitable for images where it is important that the colors are vivid and contrast well with each other. Artwork, graphics, logos, and text, as well as photographs of landscapes or still life are good candidates for the Vivid setting. This can be set for either Bitmap or Vector images.

Intense – This kicks the color intensity and saturation to the extreme. This setting does not try to keep color accurate, it's main goal is to produce deep dark colors. Artwork, graphics, logos, and text are good candidates for this setting. Some photographs will look good but typically, this setting is too intense to be used with photographs. This can be set for either Bitmap or Vector images.

ColorSure Enhancement - The ColorSure enhancement is used to replace specific colors in your image with a spot color chosen from the ColorSure palette. This resulting spot color enhancement is not affected by color setting. A ColorSure spot color will ALWAYS print the same. See Appendix C for an overview of ColorSure.

Print Palette Button – Prints the ColorSure palette for the selected substrate. ColorSure is a method for reproducing exact spot colors. The two main components are; 1) the transferred palette and 2) the CorelDraw, Corel PhotoPaint, and Adobe swatches. For a complete description on how to use ColorSure to get perfect spot colors, see appendix C.

Custom Palette Button – The Custom Palette utility enables you to add, edit, import and export custom colors to the ColorSure palette. If you need to precisely match a specific color, the Color Finder tool makes this a breeze. For a complete description on how to use the Custom Palette, refer to Appendix C.

Mirror – When you transfer an image, the result will be “flipped” when compared to the printed image. In order for your transfers to come out correctly, you must flip the image before transferring. Select this option to do the flipping for you. If you are doing this yourself in your editing application, make sure this option is turned off.

Fast Copies – This feature is for more than a single copy print job.

When selected, PowerDriver will first generate the printer data and then spool the desired number of copies.

High Speed – If the printer supports multiple resolutions, choose the most appropriate setting. For soft substrates, the High Speed option works well.

High Quality – If the printer supports multiple resolutions, choose the most appropriate setting. For hard substrates, choose the High Quality option.

Group 3 – Printer Options

Utilities – Click this button to display a utilities screen. From the utilities screen you can print a nozzle check pattern, run a print head cleaning cycle, align the printer's print head, spool a PowerDriver XG⁸ print file to the printer, and print a page of primary ink colors.

Help – This will display a help dialog box for easy an overview of the PowerDriver driver functions and settings. Also contains a link to the Sawgrass Technologies website.

Register – If the PowerDriver product has not been registered, click this button for instructions on how to register the product and unlock all the features.

Input Profile – This option allows you to specify an input profile that the driver will use when color correcting your image. If you are printing scanned artwork and your scanner manufacturer provided ICC profiles for your scanner model, select the profile here. In order to select a profile IT MUST BE INSTALLED ON YOUR MACHINE. To install a profile on your machine, locate the profile on your machine using Windows Explorer. (PowerDriver supports both ICC and ICM profile types). Right click on the profile file name and select "Install".

Appendix A: Network Printing in Windows 2000, XP

Network printing with PowerDriver in Windows 2000 and Windows XP is simple. Before a network printer can be used it must be installed on the network and shared.

Host Machine (Server)

The server machine must have installed the printer and have the printer shared. To install the networked printer, run Start | Setting | Printer | Add Printer. The Wizard will guide you through setting up the printer. When prompted, choose “Network Printer” and browse to the server machine to locate PowerDriver XG⁸.

Appendix B: Defeating Application Color Management

PowerDriver provides a complete color management solution for your SubliJet printing. ***It is extremely important that you turn off any color matching features associated with your design software.*** An explanation of how to disable print-time color management in several popular design packages follows:

CorelDraw™ version 9

1. Create a new graphic.
2. From the main menu choose Tools, Color Management. The Color Management dialog box is displayed.
3. In the Color Management window (see figure below), UNCHECK the Calibrate colors for display box.

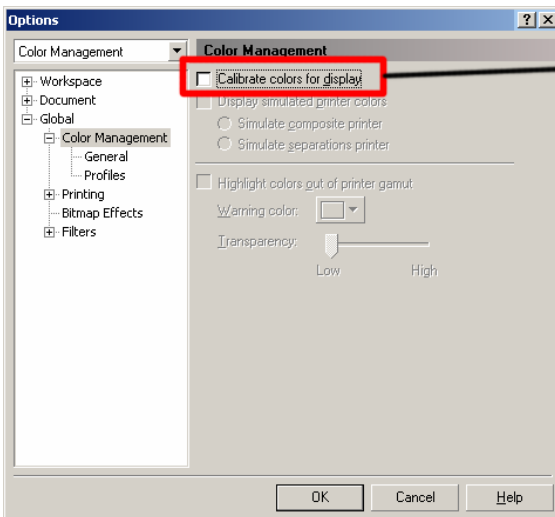

Must Be Unchecked

CoreDraw™ version 10, 11 and 12

1. Create a new graphic.
2. From the main menu choose Tools, Color Management. In the Color Management window (see figure below), set the Style option to Color Management Off.

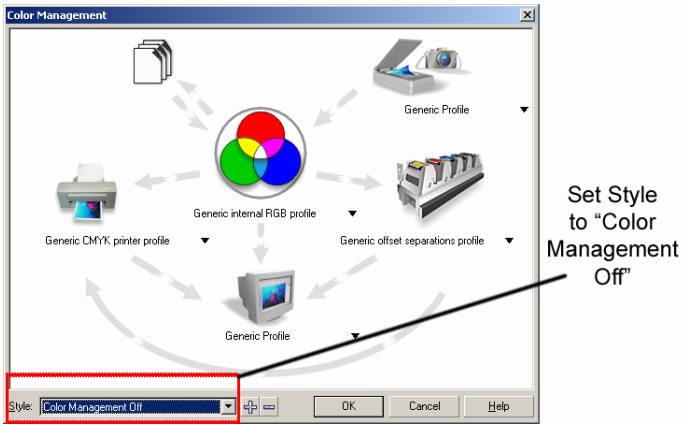

CoreDraw™ (version 5, 6, or 7)

If you are using **version 5, 6, or 7** of **CoreIDRAW**, ensure that you have the *Printer Color Profile* check box unchecked. This setting is found in the lower left of the Print dialog window. See figure below.

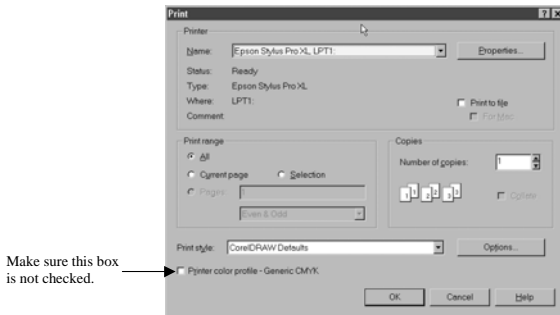

CoreIDRAW 5, 6, and 7 print dialog

Adobe Photoshop™ 6

Color Setup

From the main menu choose Edit, Color Settings. On the Color Settings dialog box:

1. Set all Color Management Policies to Off
2. Uncheck Profile Mismatches
3. Uncheck Ask When Opening.

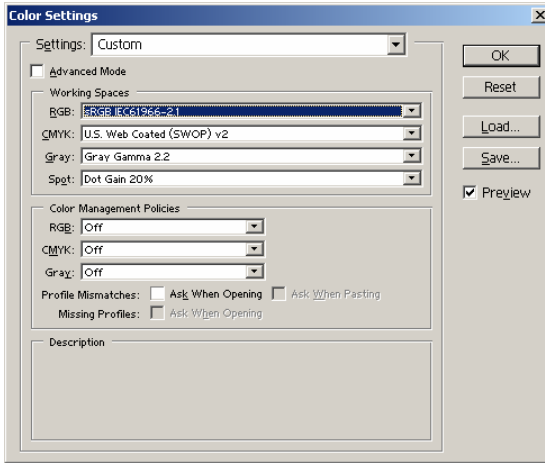

To Print RGB Graphics

Choose File, Print, and set the options as described below:

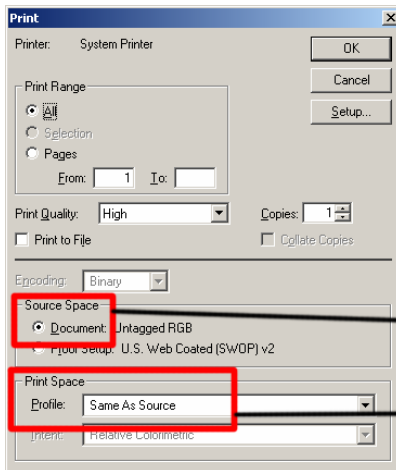

Set to Document

Set to Same As Source

To Print CMYK Graphics

Choose File, Print, and set the options as described below:

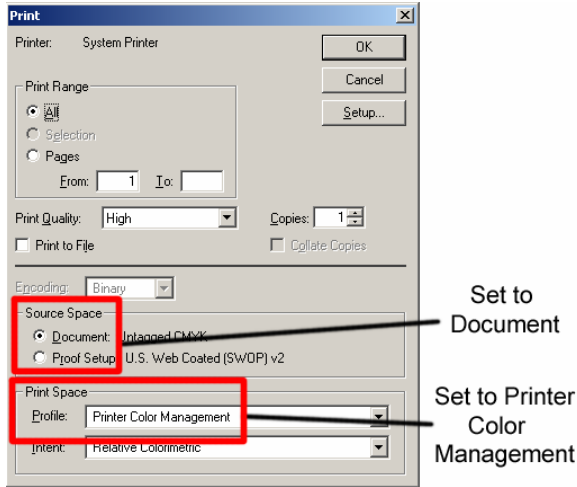

Adobe Photoshop™ 7 and CS

Color Setup

From the main menu choose Edit, Color Settings. On the Color Settings dialog box, turn all Color Management Policies off. Turn off Profile Mismatches.

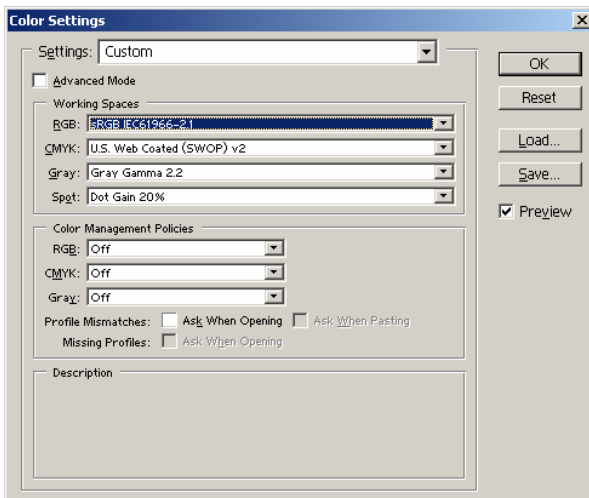

To Print:

Always select File, Print with Preview. On the print dialog page, set the options as described below:

- a. Check Show More Options
- b. Choose Color Management
- c. Choose Document as Source Space
- d. Choose Same as Source for Print Space

From the Color Management drop option list, make sure that Source is set to “Document” and Print Space is set to “Same As Source”.

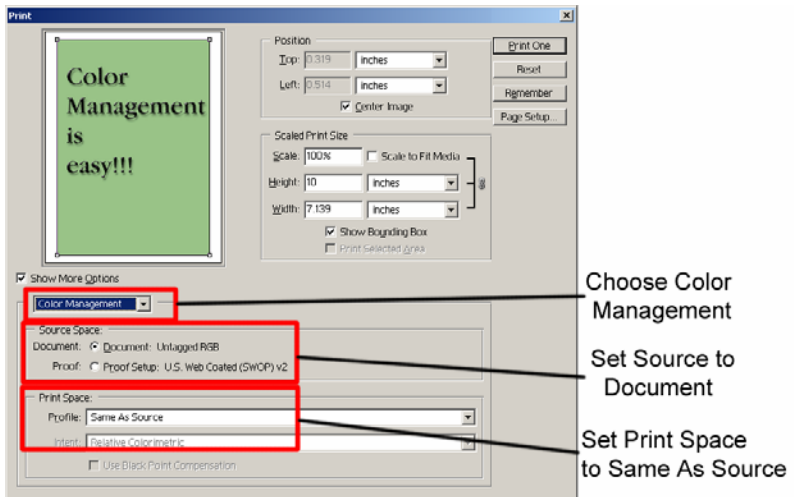

Appendix C: Using ColorSure™ and Custom Palette

I. Introduction

ColorSure is a method for reproducing exact spot colors. There are four main components of the ColorSure System: 1.) the transferred palette; 2.) Color Finder; 3.) Custom Palette; and 4.) the CorelDRAW and Adobe application palettes / swatches.

1. **ColorSure Palette:** This is your main color palette that includes a wide variety of 190 commonly used colors. To supplement this we have also included the ColorSure XG⁸ palette which consists of 160 additional colors. The XG⁸ palette is meant to take advantage of the expanded color gamut available due to the addition of red and blue inks.
2. **Color Finder:** If a color you need is not on the ColorSure palette, the Color Finder tool allows you to locate the exact custom color you are looking for.
3. **Custom Palette:** With the Custom Palette feature, you can add new custom colors to the existing ColorSure Palette mentioned in step 1.
4. **Application Palettes:** You can add your Color Finder colors to an existing application palette, or you can add multiple custom colors to new, custom palette files (*.cpl, *.acl, etc.).

II. Printing the ColorSure Palette

The first step you will want to take is to print and transfer your ColorSure palette to the various substrates you will be using. Most likely you will have customers who desire precise colors. Having your ColorSure palette available allows the customer to choose the color from the palette that is the closest match to what they want, and this gives you a starting point for finding the exact custom color that will match your customer's needs.

To print the ColorSure palette, follow the steps below:

- Click 'Start' and navigate to the 'Printers and Faxes' folder. Right-click on your PowerDriver printer and select 'Printing Preferences' from the menu. You may also open PowerDriver from within an Adobe or Corel program by going to File, Print, and choosing the PowerDriver printer from the pull-down menu. Click Properties to open PowerDriver.
- Choose the paper size you will be printing the palette to (Letter, Legal, etc)
- Choose the substrate that you will be transferring the palette to.
- Select the speed / resolution of the palette – High Speed or High Quality.
- Be sure to check the box to mirror your print, click 'Print Palette,' and then transfer the palette to the previously selected substrate.
- You now have a visual representation of how the ColorSure palette colors will appear on that particular substrate.

III. Designing Your Artwork

By picking colors from the ColorSure palette, you will be able to consistently reproduce colors in a reliable manner. To assist you in designing your artwork, PowerDriver installs three palettes: two for Adobe products and one for Corel products. These colors match the palette that is printed from within PowerDriver.

- To open the ColorSure Palette in Corel 10, 11, and 12, choose Window | Color Palettes | Open Palette. Select the file “ColorSure PDIQ V5.cpl”
- To open the ColorSure Palette in Corel 9, choose Window | Color Palette | Open Palette. Select the file “ColorSure PDIQ V5.cpl”
- To open the ColorSure Palette in Illustrator, choose Window | Swatch Libraries | Other Library. Navigate to where it was installed to when you installed PowerDriver: C:\Program Files\Sawgrass\PowerDriver\Adobe Illustrator and hit Open. *For easier access to the Palette file copy it from this [above] path to Illustrator10\Presets\Swatches and it will show up in your pull-down list directly under the Swatch Libraries menu. Other versions of Illustrator will have similar steps.*
- To open the ColorSure Palette in Adobe PhotoShop, choose the Swatches Palette, click the option arrow on the palette, choose *Replace Swatches* and pick the “ColorSure PDIQ V6.aco” file.

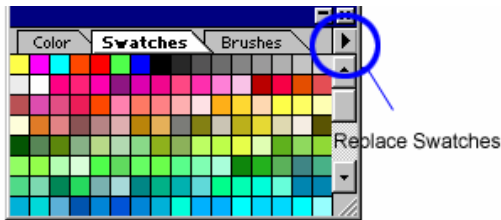

HINT

After you have the ColorSure palette loaded into CorelDraw, move the cursor over each color. As the cursor hovers over each different color, the ColorSure name is displayed in the status area at the bottom of the screen.

IV. Using Color Finder

After printing and transferring the ColorSure Palette, you see that you have an array of colors to work with. There will be times, however, when the color you need is not included in the ColorSure Palette. This is where the Color Finder tool comes in handy.

The Color Finder tool allows you to start with a specific color (e.g. navy blue) and find similar colors in the same family by adding and subtracting up to three colors called ‘Step Colors.’ For example, starting with navy blue with a CMYK value of 60,60,0,40 and choosing two step colors (e.g. cyan and magenta) would expand the original navy blue in four directions (more cyan, less cyan, more magenta, and less magenta). This expanded color chart – specific to a particular substrate and printing speed – is outputted directly to your printer.

NOTE: For PowerDriver XG⁸, you will have the added benefit of using Red and Blue with Color Finder and the Custom Color Palette.

How to use Color Finder:

- Open the PowerDriver window as instructed in “Printing the ColorSure Palette” outlined in Section II.
- First, make sure you select your desired **Substrate**, **Output** (High Speed or High Quality), and the **Mirror** option from the Printing Preferences window. Click **Apply** at the bottom of the window. This is a very important step as it will affect the final printed output.
- At the bottom of the window, click the **Custom Palette** button; this will open the **Custom Palette Utility** window.
- Click on **Color Chooser** and select your desired starting color from the matrix. If you do not wish to use Color Chooser, you have the option to manually enter the **Start Color** values in the CMYK boxes.
 - To use Color Chooser, simply click on the ‘Color Chooser’ button in the top right of the Custom Palette Utility window. You can then choose a color from the basic color selection, or you can click on the ‘Define Custom Colors’ button at the bottom of the window. This will display a color matrix. To define a custom color, click anywhere in the matrix. Use the slider at the right of the matrix to adjust luminosity. Clicking ‘OK’ will automatically fill the CMYK boxes with the corresponding values.
 - For advanced users, CMYK values can be determined by printing out a Custom Palette, which is outlined in the next section.

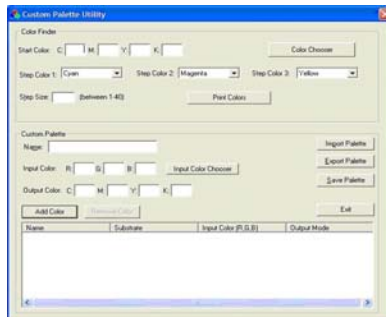

Custom Palette Utility

- You may alter the chosen color's CMYK value by selecting two or three **Step Colors**. Using multiple step colors will present you with a greater range and variety of colors to choose from.
 - For instance, if you choose to modify your Start Color with two steps, then Step Color 1 will change its values on the X (horizontal) axis and Step Color 2 will change its values on the Y (vertical) axis.

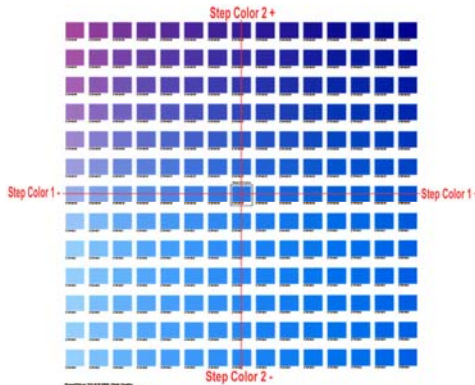

Color Finder Palette with two Step Colors

- If you modify your Start Color with three steps, Step Color 1 will remain the same. However Step Color 2 and Step Color 3 will form an imaginary 'X' and their values will change on opposing diagonal Y axes.

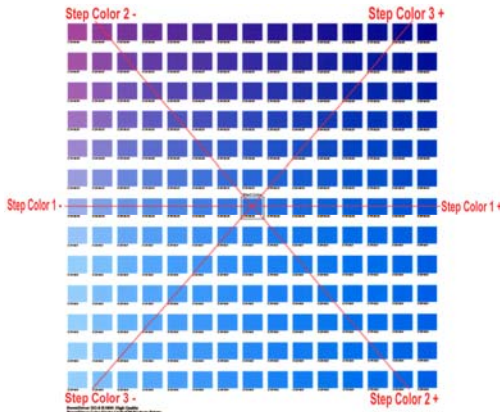

Color Finder Palette with three Step Colors

- Next, determine what **Step Size** you want to apply to the Color Finder palette. This is simply a question of how much you want your Start Color to fluctuate.
- If your Start Color is close the color you are looking for, use a low Step Size (i.e. 5-10). However, if your start color is not close to what you are looking for, use a higher Step Size. You can enter any Step Size value between 1 and 40.
 - As an example, let's say your Start Color is C:20, M:100, Y:150, K:0 and you select Cyan and Magenta to be your Step Colors. You also enter a Step Size of 10. When the 'Print Colors' button is clicked, your Start Color will be in the middle of the Color Finder palette and from there each color will vary the Cyan and Magenta values by 10.
- When you are finished selecting the Start Color, Step Colors, and the Step Size, click on the **Print Colors** button. This will print your custom Color Finder palette directly to your printer.
- After printing the Color Finder palette, transfer it to your selected substrate and then try to match your desired color to one that is on the palette. If you find a suitable match, you are finished using the Color Finder tool. Move on to **Section V. The Custom Palette**.
- If you couldn't find an accurate match on the first printed Color Finder palette, don't worry. Follow the easy steps below, and you can find a more suitable custom color.
 1. First, try to locate a new Start Color from the palette that is closer than the original color.
 2. Next, after finding a more suitable Start Color, write down that color's CMYK value. Here is how to obtain this value. There are numbers under each color that are dependant upon which Step Colors you chose. For example, it might say C:70 M:120. Take note of these values. Then, at the bottom left of the Color Finder palette you will see a full set of CMYK values. The new Start Color's CMYK value would be C:70, M:120 and whatever the YK values are from the full set.
 3. Lastly, plug the CMYK values for the new Start Color into the boxes in Color Finder, choose your Step Size, and click on Print Colors once again. Continue with steps 1-3 until you find your desired color.

V. The Custom Palette

Let us assume that you have found the exact color you need using the Color Finder tool. What you will want to do next is apply these custom color values to either an existing palette, or to create a new custom palette altogether. This allows you access to this color again should the same job arise.

How to use Custom Palette:

- First, you need to assign the CMYK values of the matched color from the Color Finder palette to the **Output Color** CMYK fields in the Custom Palette section.
- Give your new custom color a descriptive **Name** in its designated field (e.g. IBM Blue).
- Next, assign an RGB **Input Color** value. There are two methods to establish this value.
 1. If you have the original file, sample the color that was matched in your graphic design application with the eye dropper tool. This will give you the RGB value of that color. Input this value into the RGB Input Color fields of the Custom Palette section.
 2. If you do not have the original file, or the artwork has not yet been designed, simply click on the 'Input Color Chooser' button, and then click on "Define Custom Colors". From the color matrix, find a color that closely resembles the color that you are adding to the custom palette. At the bottom-right of the color matrix window are the RGB values. Simply click 'OK' and the RGB Input Color values will be automatically entered. Please take note of these RGB values for later use in your design applications.
- Click the **Add Color** button. A window will pop up asking you whether you want to add the color to the palette for all substrates, or just the current substrate. Click 'YES' here unless you have the same custom color saved on palettes for other substrates. Another window will then ask you if you want to save the custom color for all resolutions or just the current one. Click 'YES' here unless you have the same custom color saved on palettes for other resolutions.
- Lastly, click the **Save Palette** button. When finished, simply Exit out of the window.

** The 'Import Palette' and 'Export Palette' buttons are convenient to have in the event you need to transfer palettes to and from different computers.*

VI. Adding Swatches to your Application Palette:

It is possible to add your custom color(s) swatch to an application palette as well. You will need to take note of the Input Color RGB value that you assigned in the previous step in order to create the new swatch. Refer to your specific design application software's manual for instructions on this.

Appendix D: Custom Paper Sizes

Adding Custom Paper Sizes

The table below lists the minimum and maximum custom paper sizes allowable for each printer:

Printer	Minimum (W x L)	Maximum (W x L)
4800 XG ⁸	4 x 6 (in)	17 x 1200 (in)

Deleting and Modifying Custom Paper Sizes

PowerDriver uses standard Windows Print Server forms for paper size definitions. These forms can be added, deleted and maintained using the standard Windows print server properties configuration dialog.

To access the Print Server Properties dialog open the Printer and Faxes folder from the Windows control panel. Then select the **File -> Server Properties** menu item from the printer folder. The **Forms** property sheet can be used to delete and modify form properties.

Tips for Successful Sublimation



POLYESTER FABRIC

Maintain appropriate heat press times.

- Shortened pressing times will result in good surface color but the sublimation dyes will not completely penetrate the polyester fibers. This leaves the dyes more susceptible to wash out.
- Longer pressing times will cause the dye molecules to penetrate deeper into the fiber, creating a washed out look. For guidelines on transfer times, see the section entitled *Heat Transfer Instructions*.

Maintain appropriate heat press temperatures & pressure

- The correct temperature setting is vital for achieving desired results. Higher temperatures can damage the polyester fibers to the point that they cannot properly “hold” the dyes. For guidelines on transfer temperatures, see the section entitled *Heat Transfer Instructions*.
- Too much pressure on the heat press may cause the dyes to penetrate too deeply into the fabric causing a washed out look. For guidelines on transfer pressure see the section entitled *Heat Transfer Instructions*.

METAL

To obtain the best results when printing onto metal, place the transfer between the metal and an absorbent cloth or fresh, non-textured paper towel. This will absorb any dyes that pass back through the paper and any moisture released during the transfer process. If you have problems with inconsistently filled areas, this may alleviate the problem.

CERAMIC TILES & MUGS

When transferring onto ceramic tiles and mugs, immediately peel the paper off of the ceramic after removing it from the heat press. Once the paper has been removed, cool the ceramic by submerging it in cool water, or run water over it from a faucet. If paper residue remains on the surface of the ceramic, clean with citrus cleaner. If you experience a significant paper-sticking problem, call your SubliJet reseller for assistance.

Hanes Soft L'Ink® Shirts

- The presence of moisture in your fabric can lead to bleeding of the image. Remove moisture by pre-pressing your shirt for 10 seconds. Use Teflon sheets between the front and back of the shirt to prevent the inks from penetrating to the other side of the shirt. If dye residue from your heat press is being deposited on your shirts at any time, heat press a paper towel or similar absorbent material to remove it.
- Using a lint brush before pressing can greatly reduce lint or debris on the shirt.

MOISTURE & HUMIDITY PROBLEMS

The addition of moisture to the sublimation process can cause unwanted results. Under normal circumstances, the small amount of moisture that can accumulate in your paper is absorbed directly into the transfer substrate; however hard substrates like metal and ceramic are unable to absorb excess moisture. Some of the problems that are attributed to moisture include: color shifting (colors lose accuracy), bleeding of the image, and uneven transfer of solid filled areas

To avoid these problems

- Keep your paper in a dry place.
- If you suspect moisture, set the paper on your press for a few seconds. Do not press it. Just expose it to the warmth. The heat radiating from the press should help evaporate most of the moisture.
- To eliminate moisture in fabric, press the fabric for 10 seconds before doing the heat transfer.
- Use an absorbent cloth or fresh, non-textured paper towel behind the transfer sheet to absorb the moisture.

Supplies & Equipment

Contact your reseller to purchase sublimation supplies and equipment. For more information, see the Sublimation Supplies Directory on our website at www.sublimation.com.

Operating Conditions

Certain environmental conditions should be taken into account for the operation of SubliJet inks, including temperature and relative humidity.

- Supported Operating Conditions are 65° – 80° F with 40 – 60% relative humidity
- Optimum Operating Conditions are 68° – 75° F with 40 – 60% relative humidity

Storage

- Care should be taken to prevent storing SubliJet below freezing temperatures (32°F, 0°C). Do not expose SubliJet to extreme heat (temperatures in excess of 104°F, 40°C). If SubliJet has been in storage, you should allow it to reach room temperature before using it.
- Do not expose SubliJet cartridges directly to light, especially sunlight, for extended periods.
- For best results, install your SubliJet cartridges by the date on the cartridge. Please refer to the individual ink bag/cartridge for the specific ink expiration date.

Troubleshooting

The troubleshooting tips found in this section relate mainly to problems that can be seen in transferred SubliJet images. If you are having problems related to the performance of your printer, please refer to the *Problem Solving* section found in the *EPSON Stylus PRO 4800 Printer Quick Reference Guide*.

The colors in my transferred image are incorrect

- The image may need color adjustment. Use PowerDriver XG⁸ color matching software. For more information on how to use this software, please see the section entitled *PowerDriver XG⁸ User's Guide*.
- Ensure you used the right printer driver and driver settings. Please see the section entitled *PowerDriver XG⁸ User's Guide*.
- Ensure you pressed the item with the proper time, temperature, and pressure. For guidelines see the section entitled *Heat Transfer Instructions*.
- Verify all colors print correctly. Run the Nozzle Check utility and clean the print heads as required.

My printout is really light on paper

SubliJet IQ ink naturally looks muted before the heat transferring of the image. After transferring is complete, SubliJet's unique inks will produce a brilliant and durable final product.

My printout gets cut off on the bottom or side

- Verify the printer driver is setup for the correct paper size. Your printer driver setting needs to match the paper size that is loaded in your printer.
- Ensure the right paper guide is in the proper position. When setting up the printer, slide the right paper guide to the left until it clicks into position.

My image looks good but it washes out

- Ensure you pressed the garment with the proper time, temperature, and pressure. If so, try pressing longer to ensure that the dyes are penetrating the fibers sufficiently. For guidelines, see the section entitled *Heat Transfer Instructions*.
- Ensure you used a recommended paper. See the section entitled *Selecting Paper*.
- Ensure your substrate is designed to accept sublimation transfers. Garments made from natural fibers, such as cotton, are not compatible with the sublimation process.

Colors are light and splotchy

- Ensure you printed on the correct side of the paper. The print side is the bright white side of the paper.
- Ensure you used a recommended paper. For more information, see the section entitled *Selecting Paper*.
- Ensure you pressed the item with the proper time, temperature, and pressure. For guidelines, see the section entitled *Heat Transfer Instructions*.
- Verify your printer driver settings are correct. Please see the section entitled PowerDriver XG⁸ *User's Guide* for additional information.
- Ensure you do not have a moisture problem. For more information, see the section entitled *Moisture and Humidity* on the *Tips for successful Sublimation* page.
- Ensure your substrate is designed to accept a sublimation transfer. Garments made from natural fibers such as Cotton are not compatible with the sublimation process.

My image looks blurred

- Ensure you pressed the item with the proper time, temperature, and pressure. For guidelines, see the section entitled *Heat Transfer Instructions*.
- Ensure you used a recommended paper. For more information, see the section entitled *Selecting Paper*.

- Ensure you printed on the correct side of the paper. The print side is the bright white side of the paper.
- Ensure you do not have a moisture problem. Try drying the paper on the press or putting a paper towel behind the transfer when you heat press it. Read the section entitled *Moisture and Humidity* on the *Tips for Successful Sublimation* page.
- Verify that the printer's print heads are properly aligned. For further instructions, see the *EPSON Stylus PRO 4800 Printer Quick Reference Guide*.

My image has gaps or bands present

- Ensure that all of the printer's nozzles are firing properly. Perform a Nozzle Check from the *Utility* tab of your printer driver. For further instructions, see the *EPSON Stylus PRO 4800 Printer Quick Reference Guide*.
- If one or more of the nozzles fail to print, perform a Print Head Cleaning. For further instructions, see the *EPSON Stylus PRO 4800 Printer Quick Reference Guide*.

Technical Support

If you are having difficulties achieving good results from your SubliJet IQ™ inks, you have several support options:

1. **Telephone:** You may contact your authorized SubliJet reseller during their normal hours of operation for assistance. A full listing of authorized SubliJet Resellers is available on our Web site at www.sublimation.com. In addition, you may also contact Sawgrass Technical Support at (843) 884-1575 between the hours of 8:00 AM and 5:30 PM Eastern Standard Time.
2. **Internet:** Visit the *Technical Support* area of the Sawgrass Technologies, Inc. website at www.sublimation.com. The troubleshooting utility found here will provide you with solutions to some of the most common problems. You may submit a detailed description of your problem if you need further assistance.
3. **E-mail:** You may e-mail Sawgrass Technical Support with a detailed description of your problem at support@sublimation.com.
4. **Fax:** You may fax a detailed description of your problem to Sawgrass Technical Support at (843) 849-3847.

Project Sublimation

Whether you are a current business owner adding sublimation to your line-up, a novice/intermediate sublimation user who would like to learn more, or an entrepreneur exploring the dye-sub industry, Project Sublimation is the industry's choice for practical, hands-on instruction. From equipment and product overview to marketing and pricing your products; from the science of sublimation to color management, our two-day, interactive workshop series will give you the background and know-how needed to run a full-service sublimation business.

At Project Sublimation workshop events, you will also have the opportunity to network with fellow sublimation users across the US and Canada. The new, enhanced Project Sublimation web site gives attendees access to the full business assets and forums, an invaluable resource for growing your sublimation business.

Isn't it time you took your business to the next level?

Project Sublimation travels to cities throughout the United States and Canada. Join us in a city near you for this dynamic, full-service workshop. Spend two days with one of our experts and get a leg up on your competition.

Please visit us on the web at www.ProjectSublimation.com or phone us toll free at 1.888.780.7349